

COPPER VIEW

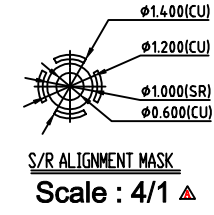

- NOTE:
- 1:GENERAL TOLERANCE :±0.050MM
 - 2:ALL CHAMFER IS R0.20
 - 3:MATERIAL
PI :UPILEXS 75±8um THICKNESS
ADHESIVE:TORAY #7100 12±4um THICKNESS
CU :SLP 25±5 um
SOLDER RESIST:AE-70-M11 26±14um
OTHER TOLERANCE ±0.300
 - 4:PLATING
SN:0.21±0.05um
 - 5:6 SPROCKET HOLES(28.5MM) FOR 1 TAPESITE

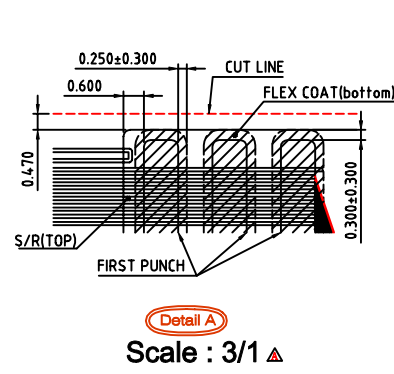
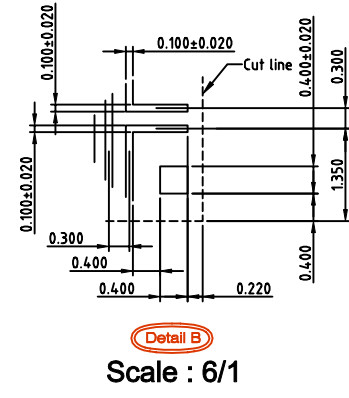
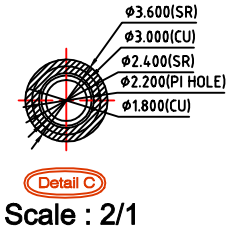
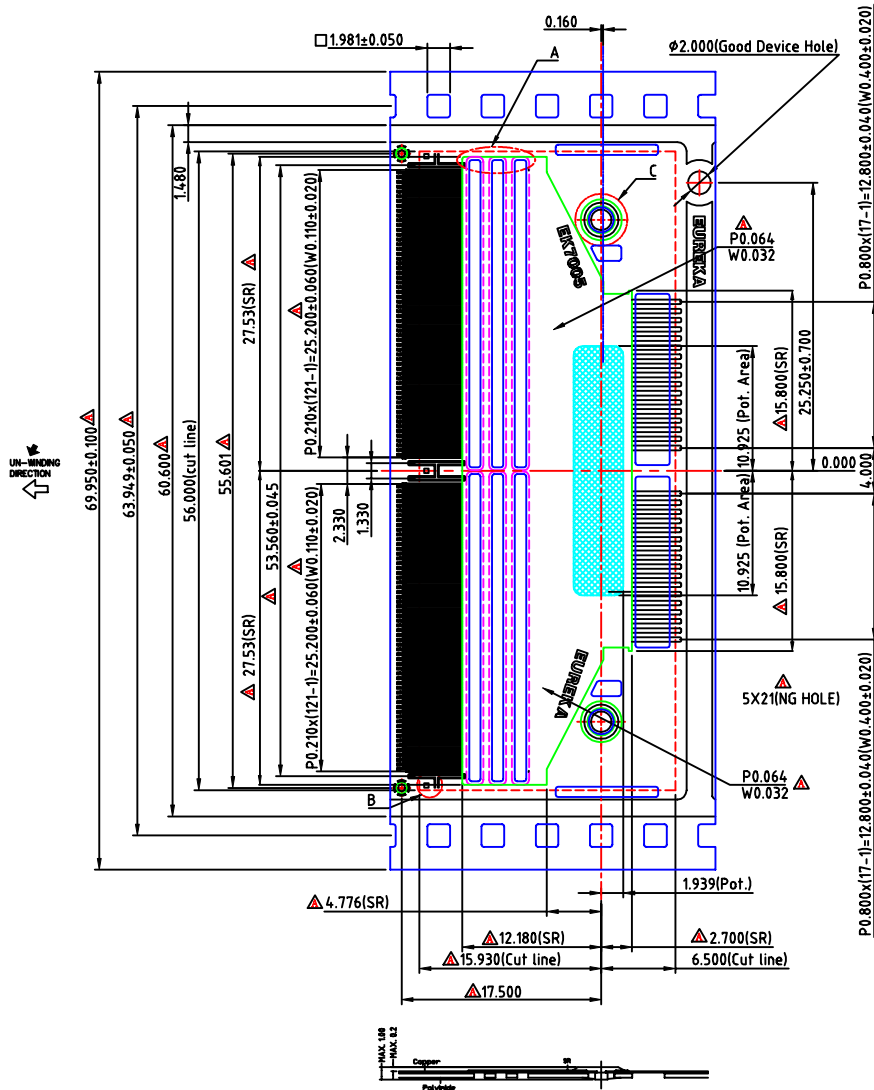
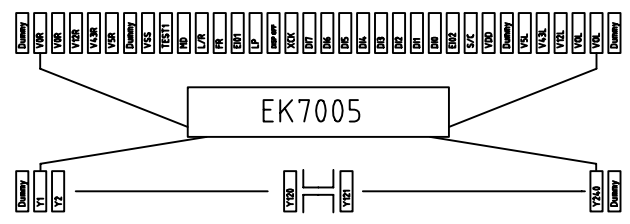
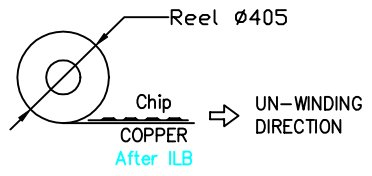

Unless Otherwise Specified		Eureka Microelectronics, Inc. 天鈺科技股份有限公司			Scale	2.5 : 1	Proj	⊕
Unit	mm				SUBPACK CODE 1SSPTC417001			
General Roughness		EK7005 Outline Drawing			Material PI			
Tolerance		Drawn	Checked	Approved	Drawing No		Rev	
Dimension	± 0.1	By	Jenny Chu		WUTC417001		1	
Angle	± 1'	Date	05-12-00'		Sheet	1 Of 1	Size	A4