

---

# HD66720

(Panel Controller/Driver for Dot-Matrix Liquid Crystal Display  
with Key-Matrix)

# HITACHI

---

## Description

The HD66720 dot-matrix liquid crystal display controller (LCD) and driver LSI incorporates a key-scan function and an LED display function, and displays alphanumeric character and symbols. A single HD66720 is capable of displaying a single 10-character line or two 8-character lines. In addition, a single line of up to 40 characters can be displayed with extension drivers.

Since the HD66720 incorporates a  $5 \times 6$  matrix key scan circuit and two LED drive circuits, it can control front panels of telephone, car stereos, audio equipment, printers, or facsimiles with a single chip. A three-line clock synchronous serial transfer method is adopted for interfacing with a microcomputer, which greatly decreases the number of interface signals and makes it easy to miniaturize systems.

This LSI is especially suitable for panels which can display five European languages (English, French, German, Italian, and Spanish), as used in new media products including car tuners for the radio data system (RDS), personal handy phone, digital cordless phone, cellular phone.

## Features

- Control and drive of a dot matrix LCD with built-in scanning
- Wide field-of-division display with low duty cycle of 1/9 (1 line) and 1/17 (2 lines)
- 10-character single line ( $5 \times 8$ -dot font) and 50-segment display with a single chip (two 8-character line display by setting a register)
- Maximum 40-character single line display with extension drivers (see List 1)
- Built-in key scan matrix buffer circuit:  $5 \times 6$  (30 keys) input (at strobe cycle: 5 ms to 40 ms,  $f_{osc} = 160$  kHz)
- Wake-up function with IRQ signal after key stroke
- Two general purpose output ports (for LED displays, etc.)
- Serial bus interface: Three-line clock synchronous serial transfer
- Booster for liquid crystal drive voltage: Two/three times power supply
- Maximum 40-character display RAM

HITACHI

## HD66720

- Character generator ROM: 240 5 × 8-dot characters
- Character generator RAM: 8 user characters
- 80-segment RAM
- Horizontal smooth scroll: Displayed line selection and displayed character selection scroll possible
- Oscillator (external resistor needed) and power-on reset circuit incorporated
- Wide range of operating power supply voltage: 2.7 to 5.5V  
Liquid crystal display voltage: 3.0 to 11.0V
- QFP 1420-100 (0.65-mm pitch), TQFP 1414-100 (0.5-mm pitch), bare-chip

### List 1 Programmable Duty Cycles

Number of Lines	Duty Ratio	5-Dot Font Width					
		Single-Chip Operation		With Single 40-Output Extension Driver		Maximum Display Extension	
		Displayed Characters	Segments	Displayed Characters	Segments	Displayed Characters	Segments
1	1/9	10	50	18	80	40	80
2	1/17	8	42	16	80	20	82

Number of Lines	Duty Ratio	6-Dot Font Width					
		Single-Chip Operation		With Single 40-Output Extension Driver		Maximum Display Extension	
		Displayed Characters	Segments	Displayed Characters	Segments	Displayed Characters	Segments
1	1/9	8	50	15	90	40	96
2	1/17	7	42	13	82	20	96

### List 2 Ordering Information

Type No.	Package	Supply Voltage	CGROM
HD66720A03FS	FP-100A	2.7 to 5.5V	Japanese + European font
HD66720A03TF	TFP-100B		
HCD66720A03	Chip		
HD66720A02TF*	TFP-100B		European font

Note: \* Development to be planned.

**LCD-II Family Comparison**

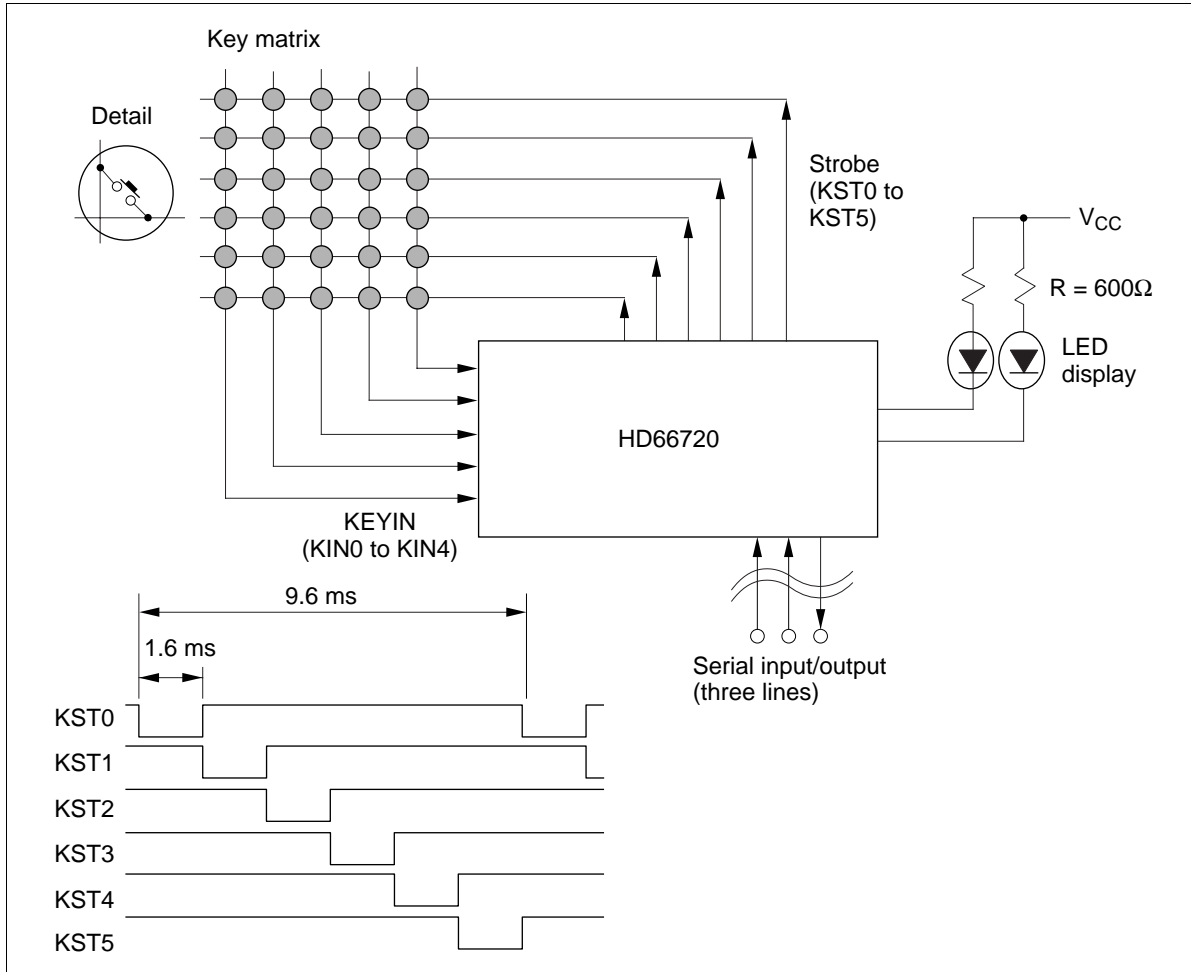
<b>Item</b>	<b>LCD-II (HD44780U)</b>	<b>HD66702R</b>	<b>HD66710</b>	<b>HD66712U</b>
Power supply voltage	2.7V to 5.5V	5 V ± 10% (standard) 2.7V to 5.5V (low voltage)	2.7V to 5.5V	2.7V to 5.5V
Liquid crystal drive voltage	3.0 to 11.0V	3.0V to 8.3V	3.0 to 13.0V	2.7 to 11.0V
Maximum display - characters per chip	8 characters × 2 lines	20 characters × 2 lines	16 characters × 2 lines/ 8 characters × 4 lines	24 characters × 2 lines/ 12 characters × 4 lines
Segment display	None	None	40	60 (extended to 80)
Display duty ratio	1/8, 1/11, and 1/16	1/8, 1/11, and 1/16	1/17 and 1/33	1/17 and 1/33
CGROM	9,920 bits (208 5-×-8 dot characters and 32 5-×-10 dot characters)	7,200 bits (160 5-×-7 dot characters and 32 5-×-10 dot characters)	9,600 bits (240 5-×-8 dot characters)	9,600 bits (240 5-×-8 dot characters)
CGRAM	64 bytes	64 bytes	64 bytes	64 bytes
DDRAM	80 bytes	80 bytes	80 bytes	80 bytes
SEGRAM	None	None	8 bytes	16 bytes
Segment signals	40	100	40	60
Common signals	16	16	33	34
Liquid crystal drive waveform	A	B	B	B
Clock source	External resistor or external clock	External resistor or external clock	External resistor or external clock	External resistor or external clock
Rf oscillation frequency	270 kHz ± 30%	320 kHz ± 30%	270 kHz ± 30%	270 kHz ± 30%
Liquid crystal voltage booster circuit	None	None	Double or triple booster circuit	Double or triple booster circuit
Liquid crystal drive operational amplifier	None	None	None	None
Bleeder-resistor for liquid crystal drive	External	External	External	External
Liquid crystal contrast adjuster	None	None	None	None
Key scan circuit	None	None	None	None
Extension driver control signal	Independent control signal	Independent control signal	Used in common with a driver output pin	Independent control signal
Reset function	Internal reset circuit	Internal reset circuit	Internal reset circuit	Internal reset circuit or reset input
Horizontal smooth scroll	Impossible	Impossible	Dot unit	Dot unit and line unit
Vertical smooth scroll	Impossible	Impossible	Impossible	Impossible
Number of displayed lines	1 or 2	1 or 2	1, 2, or 4	1, 2, or 4
Low power control	None	None	Low power mode	Low power mode
Bus interface	4 or 8 bits	4 or 8 bits	4 or 8 bits	Serial, 4, or 8 bits
Package	80-pin QFP1420 80-pin TQFP1414 80-pin bare chip	144-pin FQFP2020 144-pin bare chip	100-pin QFP1420 100-pin TQFP1414 100-pin bare chip	128-pin TCP 128-pin bare chip

## HD66720

### LCD-II Family Comparison (cont)

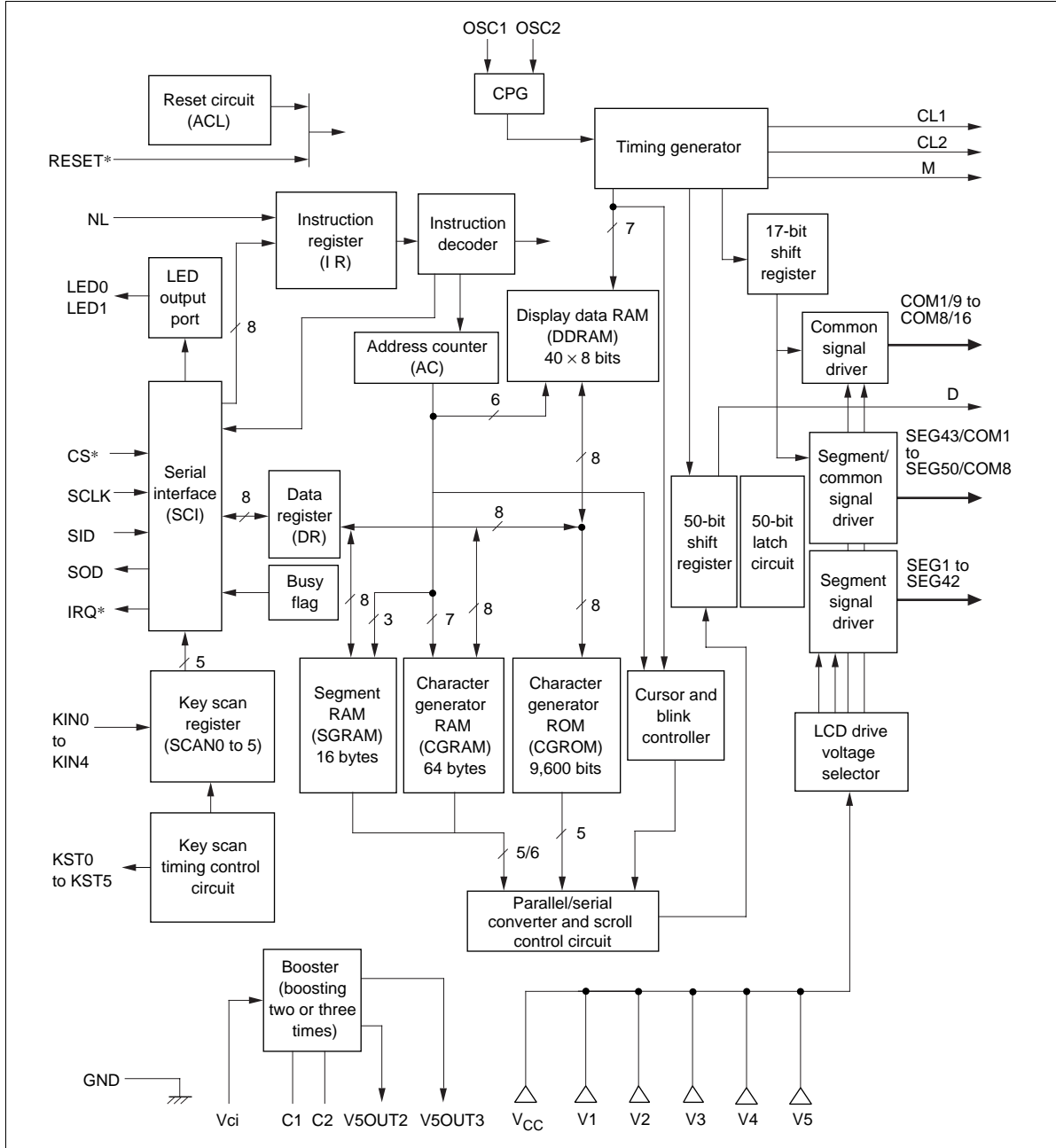
Item	HD66720	HD66717	HD66727
Power supply voltage	2.7V to 5.5V	2.4V to 5.5V	2.4V to 5.5V
Liquid crystal drive voltage	3.0 to 11.0V	3.0 to 13.0V	3.0 to 13.0V
Maximum display characters per chip	10 characters × 1 line/ 8 characters × 2 lines	12 characters × 1 line/2 lines/3 lines/4 lines	12 characters × 1 line/2 lines/3 lines/4 lines
Segment display	42 (extended to 80)	40 (and 10 annunciators)	40 (and 12 annunciators)
Display duty ratio	1/9 and 1/17	1/10, 1/18, 1/26, and 1/34	1/10, 1/18, 1/26, and 1/34
CGROM	9,600 bits (240 5-×-8 dot characters)	9,600 bits (240 5-×-8 dot characters)	11,520 bits (240 6-×-8 dot characters)
CGRAM	64 bytes	32 bytes	32 bytes
DDRAM	40 bytes	60 bytes	60 bytes
SEGRAM	16 bytes	8 bytes	8 bytes
Segment signals	42	60	60
Common signals	17	34	34
Liquid crystal drive waveform	B	B	B
Clock source	External resistor or external clock	External resistor or external clock	External resistor or external clock
Rf oscillation frequency	160 kHz ± 30%	1-line mode: 40 kHz ± 30% 2-line mode: 80 kHz ± 30% 3-line mode: 120 kHz ± 30% 4-line mode: 160 kHz ± 30%	1-line mode: 40 kHz ± 30% 2-line mode: 80 kHz ± 30% 3-line mode: 120 kHz ± 30% 4-line mode: 160 kHz ± 30%
Liquid crystal voltage booster circuit	Double or triple booster circuit	Double or triple booster circuit	Double or triple booster circuit
Liquid crystal drive operational amplifier	None	Built-in for each V1 to V5	Built-in for each V1 to V5
Bleeder-resistor for liquid crystal drive	External	Internal 1/4 and 1/6 bias resistors	Internal 1/4 and 1/6 bias resistors
Liquid crystal contrast adjuster	None	Incorporated	Incorporated
Key scan circuit	5 × 6 = 30 keys	None	4 × 8 = 32 keys
Extension driver control signal	Independent control signal	None	None
Reset function	Internal reset circuit or reset input	Reset input	Reset input
Horizontal smooth scroll	Dot unit and line unit	Impossible	Impossible
Vertical smooth scroll	Impossible	Dot (raster-row) unit	Dot (raster-row) unit
Number of displayed lines	1 or 2	1, 2, 3, or 4	1, 2, 3, or 4
Low power control	Low power mode and sleep mode	Standby mode and sleep mode	Standby mode and sleep mode
Bus interface	Serial	I <sup>2</sup> C, serial, 4, or 8 bits	I <sup>2</sup> C or clock-synchronized serial
Package	100-pin QFP1420 100-pin TQFP1414 100-pin bare chip	Slim chip with/without bumps TCP	Slim chip with/without bumps TCP

Key Input Sampling and LED Display



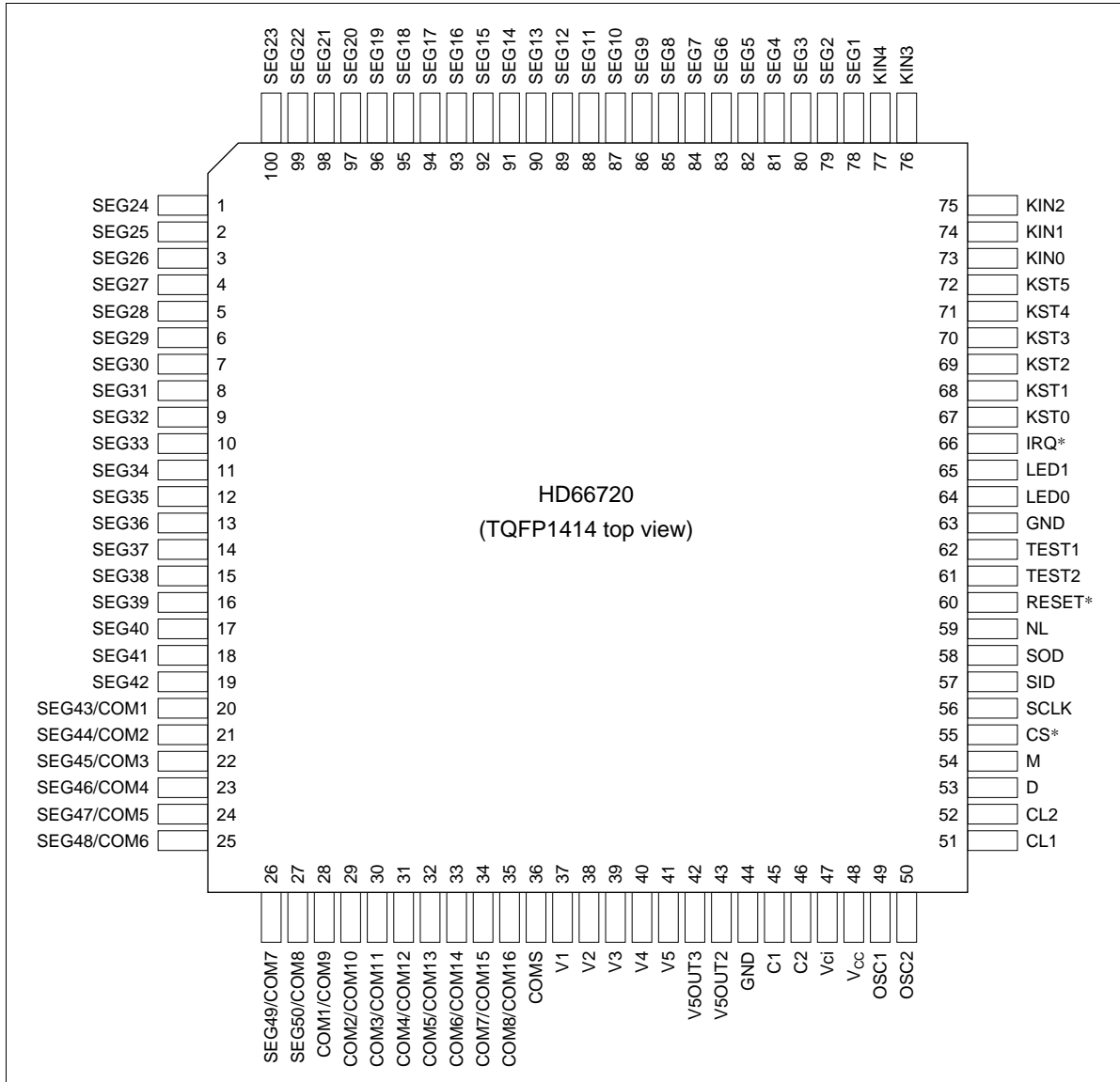
# HD66720

## Block Diagram

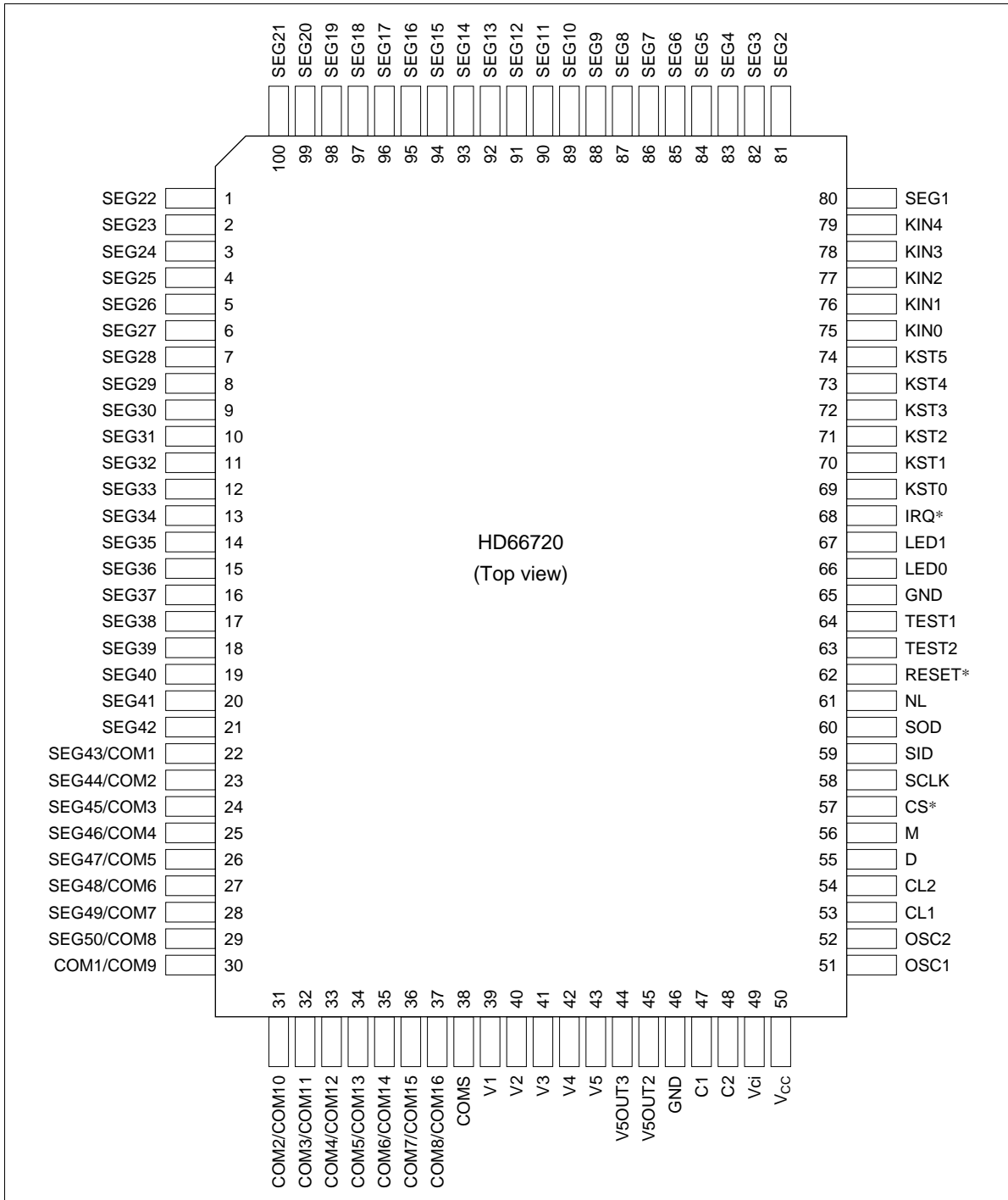


HITACHI

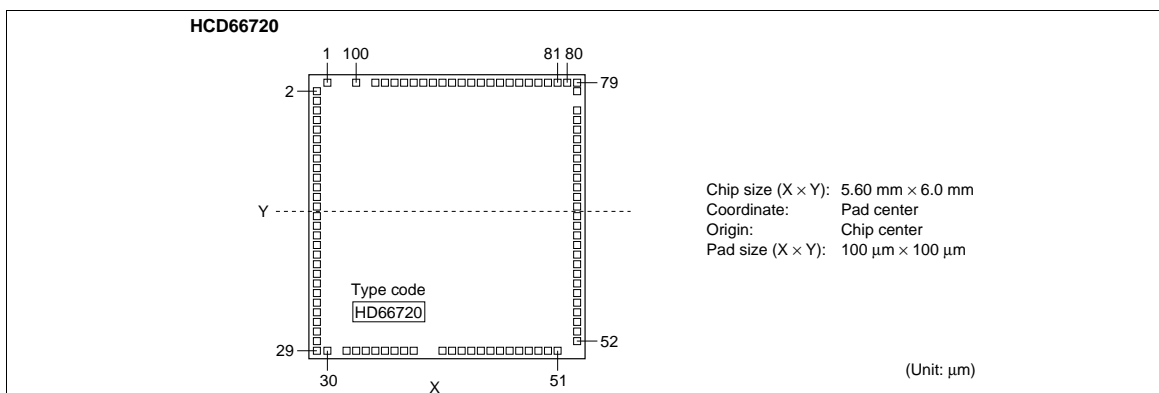
Pin Arrangement



# HD66720



**HITACHI**



Pad No.	Function	Coordinate		Pad No.	Function	Coordinate		Pad No.	Function	Coordinate	
		X	Y			X	Y			X	Y
1	SEG22	-2400	2877	35	COM6/COM14	-1100	-2877	69	KST0	2653	730
2	SEG23	-2677	2700	36	COM7/COM15	-900	-2877	70	KST1	2653	920
3	SEG24	-2677	2500	37	COM8/COM16	-700	-2877	71	KST2	2653	1110
4	SEG25	-2677	2300	38	COMS	-500	-2877	72	KST3	2653	1300
5	SEG26	-2677	2100	39	V1	-150	-2853	73	KST4	2653	1500
6	SEG27	-2677	1900	40	V2	100	-2853	74	KST5	2653	1700
7	SEG28	-2677	1700	41	V3	300	-2853	75	KIN0	2653	1900
8	SEG29	-2677	1500	42	V4	500	-2853	76	KIN1	2653	2100
9	SEG30	-2677	1300	43	V5	800	-2853	77	KIN2	2653	2300
10	SEG31	-2677	1100	44	V5OUT3	1020	-2809	78	KIN3	2653	2653
11	SEG32	-2677	900	45	V5OUT2	1200	-2809	79	KIN4	2653	2853
12	SEG33	-2677	700	46	GND	1400	-2790	80	SEG1	2400	2877
13	SEG34	-2677	500	47	C1	1600	-2853	81	SEG2	1900	2877
14	SEG35	-2677	300	48	C2	1800	-2809	82	SEG3	1700	2877
15	SEG36	-2677	100	49	VCI	2000	-2809	83	SEG4	1500	2877
16	SEG37	-2677	-100	50	VCC	2200	-2853	84	SEG5	1300	2877
17	SEG38	-2677	-300	51	OSC1	2400	-2853	85	SEG6	1100	2877
18	SEG39	-2677	-500	52	OSC2	2653	-2700	86	SEG7	900	2877
19	SEG40	-2677	-700	53	CL1	2653	-2500	87	SEG8	700	2877
20	SEG41	-2677	-900	54	CL2	2653	-2300	88	SEG9	500	2877
21	SEG42	-2677	-1100	55	D	2653	-2100	89	SEG10	300	2877
22	SEG43/COM1	-2677	-1300	56	M	2653	-1900	90	SEG11	100	2877
23	SEG44/COM2	-2677	-1500	57	CS*	2653	-1700	91	SEG12	-100	2877
24	SEG45/COM3	-2677	-1700	58	SCLK	2653	-1500	92	SEG13	-300	2877
25	SEG46/COM4	-2677	-1900	59	SID	2653	-1300	93	SEG14	-500	2877
26	SEG47/COM5	-2677	-2100	60	SOD	2653	-1100	94	SEG15	-700	2877
27	SEG48/COM6	-2677	-2300	61	NL	2653	-900	95	SEG16	-900	2877
28	SEG49/COM7	-2677	-2677	62	RESET*	2653	-700	96	SEG17	-1100	2877
29	SEG50/COM8	-2677	-2877	63	TEST2	2653	-500	97	SEG18	-1300	2877
30	COM1/COM9	-2400	-2877	64	TEST1	2653	-300	98	SEG19	-1500	2877
31	COM2/COM10	-1900	-2877	65	GND	2653	-30	99	SEG20	-1700	2877
32	COM3/COM11	-1700	-2877	66	LED0	2653	174	100	SEG21	-1900	2877
33	COM4/COM12	-1500	-2877	67	LED1	2653	350				
34	COM5/COM13	-1300	-2877	68	IRQ*	2653	540				

# HD66720

## Pin Functions

**Table 1 Pin Functional Description**

Signal	Number of Pins	I/O	Device Interfaced with	Function
CS*	1	I	MPU	Acts as chip-select during serial mode: Low: Select (access enable) High: Not selected (access disable)
SCLK	1	I	MPU	Acts as a serial clock input (receive).
SID	1	I	MPU	Inputs serial data during serial mode.
IRQ*	1	O	MPU	Generates key scan interrupt signal.
SOD	1	O	MPU	Outputs (transmits) serial data during serial mode. Open this pin if reading (transmission) is not performed.
SEG1 to SEG42	42	O	LCD	Acts as a segment output signal.
SEG43/COM1 to SEG50/COM8	8	O	LCD	Acts as segment output during 1-line display mode. Acts as common output during 2-line display mode.
COM1/COM9 to COM8/COM16	8	O	LCD	Acts as common output during 1-line display mode. Acts as common output during 2-line display mode.
COMS	1	O	LCD	Common output signal for segment (icon).
CL1	1	O	Extension driver	Outputs the extension driver latch pulse.
CL2	1	O	Extension driver	Outputs the extension driver shift clock.
D	1	O	Extension driver	Outputs extension driver data; data from the 51st dot on is output during single-line display, and data from the 43rd dot on is output during two-line display.
M	1	O	Extension driver	Outputs the extension driver AC signal.
KST0* to KST5*	6	O	Key matrix	Generates strobe signals for latching data from the key matrix at specific time intervals.
KIN0* to KIN4*	5	I	Key matrix	Samples key state from key matrix synchronously with strobe signals.
LED0* to LED1*	2	O	LEDs	LED display control signals; can also be used as a general output port.
V1 to V5	5	—	Power supply	Power supply for LCD drive $V_{CC} - V5 = 11V$ (max)
$V_{CC}$ /GND	2	—	Power supply	$V_{CC}$ : +2.7V to +5.5V, GND: 0V
OSC1/OSC2	2	—	Oscillation resistor clock	When crystal oscillation is performed, an external resistor must be connected. When the pin input is an external clock, it must be input to OSC1.

**Table 1 Pin Functional Description (cont)**

Signal	Number of Pins	I/O	Device Interfaced with	Function
Vci	1	I	—	Inputs voltage and power supply to the booster to generate the liquid crystal display drive voltage. Keep this voltage within the range: 1.0V to 5.0V without exceeding $V_{CC}$ .
V5OUT2	1	O	V5 pin/Booster capacitor	Voltage input to the Vci pin is boosted twice and output. When the voltage is boosted three times, the same capacitance as that of C1–C2 should be connected here.
V5OUT3	1	O	V5 pin	Voltage input to the Vci pin is boosted three times and output.
C1/C2	2	—	Booster capacitor	External capacitor should be connected here when using the booster.
RESET*	1	I	—	Reset pin. When active (low), this pin turns the display off and initializes the registers.
NL	1	I	—	Number of display lines. One line is displayed when this pin is low (1/9 duty), and two lines are displayed when this pin is high (1/17 duty).
TEST	2	I	—	Test pin. Should be wired to ground.

---

## HD66720

---

### Block Function

#### System Interface

The HD66720 interfaces with the system through a three-line clock-synchronous serial method. This greatly decreases the number of interface connections with the MPU because all data transmission/reception, such as setting registers, writing data to RAM, and reading key-scan data can be performed with three control signals.

The HD66720 has two 8-bit registers: an instruction register (IR) and a data register (DR).

The IR stores instruction codes, such as display clear and cursor shift, and address information for the display data RAM (DDRAM), the character generator RAM (CGRAM), and the segment RAM (SEGRAM). The IR can only be written to by the MPU, and cannot be read from.

The DR temporarily stores data to be written into DDRAM, CGRAM, or SEGRAM. Data written into the DR from the MPU is automatically written into DDRAM, CGRAM, or SEGRAM by an internal operation. The DR is also used for data storage when reading data from DDRAM, CGRAM, or SEGRAM. When address information is written into the IR, data is read and then stored into the DR from DDRAM, CGRAM, or SEGRAM by an internal operation. Data transfer between the MPU is then completed when the MPU reads the DR. After the read, data in DDRAM, CGRAM, or SEGRAM at the next address is sent to the DR for the next read from the MPU.

These two registers can be selected by the RS bit in start byte data in synchronized serial interface (Table 2). For detail, refer to Transferring Serial Data.

#### Busy Flag (BF)

When the busy flag is 1, the HD66720 is in the internal operation mode, and the next instruction will not be accepted. When RS = 0 and R/W = 1 (Table 2), the busy flag is output from DB7. The next instruction must be written after ensuring that the busy flag is 0.

#### Key Scan Register (SCAN0 to SCAN5)

Scanning from the key matrix senses the key state at the rising edge of key strobe signals (KST0 to KST5) output from the HD66720. These strobe signals sample 5 states: KIN0 to KIN4, enabling key scan of 30 types.

Key states KIN0 to KIN4 sampled by key strobe signal KST0 is latched to register SCAN0. In the same way, data sampled with strobe signals KST1 to KST5 are latched to registers SCAN1 to SCAN5, respectively. For details, refer to Key Scan Control.

**Table 2 Register Selection**

<b>RS</b>	<b>R/W</b>	<b>Operation</b>
0	0	IR write as an internal operation (display clear, etc.)
0	1	Read busy flag (DB7) and key scan register (DB0 to DB4)
1	0	DR write as an internal operation (DR to DDRAM, CGRAM, or SEGRAM)
1	1	DR read as an internal operation (DDRAM, CGRAM, or SEGRAM to DR)

### Address Counter (AC)

The address counter (AC) assigns addresses to DDRAM, CGRAM, or SEGRAM. When an address of an instruction is written into the IR, the address information is sent from the IR to the AC. Selection of DDRAM, CGRAM, and SEGRAM is also determined concurrently by the instruction.

After writing into (reading from) DDRAM, CGRAM, or SEGRAM, the AC is automatically incremented by 1 (decremented by 1).

### Display Data RAM (DDRAM)

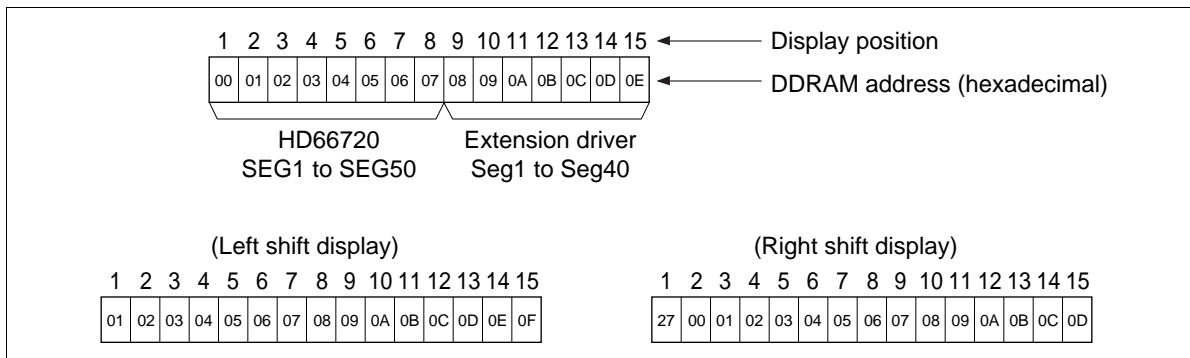
Display data RAM (DDRAM) stores display data represented in 8-bit character codes. Its capacity is  $40 \times 8$  bits, or 40 characters. The area in display data RAM (DDRAM) that is not used for display can be used as buffer data RAM when scrolling.

The DDRAM address (ADD) is set in the address counter (AC) as a hexadecimal number, as shown in Figure 1.

The relationship between DDRAM addresses and positions on the liquid crystal display is described and shown on the following pages for a variety of cases.

- 1-line display (NL = low)
  - Case 1: When there are fewer than 40 display characters, the display begins at the beginning of DDRAM. For example, when 10 5-dot font-width characters are displayed using one HD66720, the display is generated as shown in Figure 3.
    - When a display shift is performed, the DDRAM addresses shift as shown.
    - When 8 6-dot font-width characters are displayed using one HD66720, the display is generated as shown in Figure 3.
    - When a display shift is performed, the DDRAM addresses shift as shown.
  - Case 2: Figure 4 shows the case where the HD66720 and the 40-output extension driver are used to display 15 6-dot font-width characters.
    - When a display shift is performed, the DDRAM addresses shift as shown in the figure.





**Figure 4 1-Line by 15-Character Display (6-Dot Font) Using One HD66720 and One Extension Driver**

## HD66720

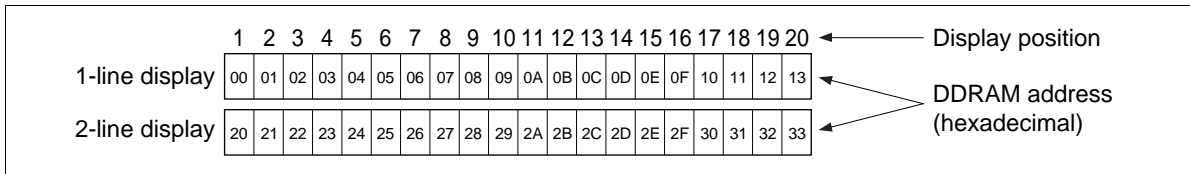
- 2-line display (NL = 1)

- Case 1: The first line is displayed from COM1 to COM8, and the second line is displayed from COM9 to COM16. Note that the last address of the first line and the first address of the second line are not consecutive. Figure 6 shows an example where a 5-dot font-width  $8 \times 2$ -line display is performed using one HD66720.

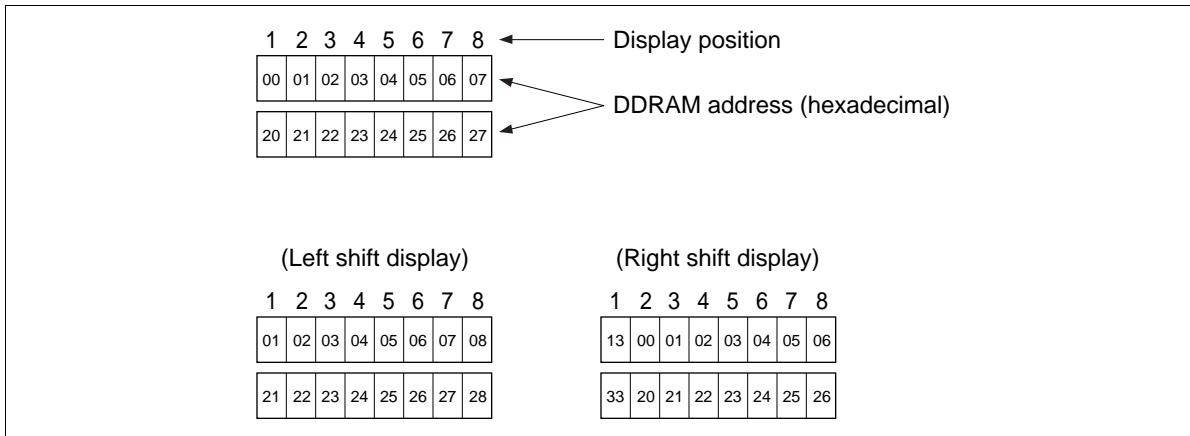
When a display shift is performed, the DDRAM addresses shift as shown.

- Case 2: Figure 6 shows an example where a 5-dot font-width  $16 \times 2$ -line display is performed using one HD66720 and one extension driver.

When a display shift is performed, the DDRAM addresses shift as shown.



**Figure 5 2-Line Display**



**Figure 6 2-Line 8-Character Display (5-Dot Font) Using One HD66720**

**Character Generator ROM (CGROM)**

The character generator ROM generates  $5 \times 8$  dot character patterns from 8-bit character codes (Table 3 to 5). It can generate 240  $5 \times 8$  dot character patterns. User-defined character patterns are also available using a mask-programmed ROM (see Modifying Character Patterns).

**Character Generator RAM (CGRAM)**

The character generator RAM allows the user to redefine the character patterns. In the case of  $5 \times 8$  characters, up to eight may be redefined.

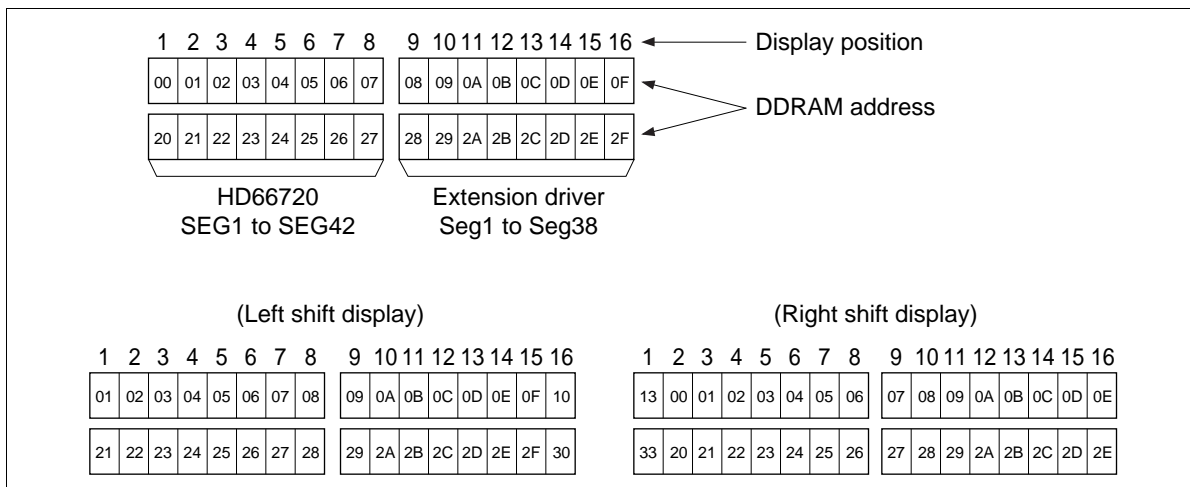
Write the character codes at the addresses shown as the left column of Table 6 to show the character patterns stored in CGRAM.

See Table 6 for the relationship between CGRAM addresses and data and display patterns.

**Segment RAM (SEGRAM)**

The segment RAM (SEGRAM) is used to enable control of segments such as an icon and a mark by the user program. Data is read from SEGRAM and is output via the COMS pin to perform segment display. As shown in Table 7, bits in SEGRAM corresponding to segments to be displayed are directly set by the MPU, regardless of the contents of DDRAM and CGRAM. Scrolling or display shifting will not be performed.

SEGRAM data is stored in eight bits. The lower six bits control the display of each segment, and the upper two bits control segment blinking.



**Figure 7 2-Line by 16-Character Display Using One HD66720 and One Extension Driver**

---

## **HD66720**

---

### **Timing Generator**

The timing generator generates timing signals for the operation of internal circuits such as DDRAM, CGROM, CGRAM, and SEGRAM. RAM read timing for display and internal operation timing by MPU access are generated in a time sharing method. Therefore, when writing data to DDRAM, for example, there will be no undesirable interferences, such as flickering, in areas other than the display area.

### **Liquid Crystal Display Driver Circuit**

The liquid crystal display driver circuit consists of common signal drivers and segment signal drivers. For a 1-line display, there will be 9 common signals and 16 segment signals. For a 2-line display, there will be 17 common signals and 42 segment signals. If the NL pin is set, display lines can be selected automatically.

Character pattern data is sent serially through a 50-bit (42-bit) shift register and latched when all needed data has arrived. The latched data then enables the LCD driver to generate drive waveform outputs.

Sending serial data always starts at the display data character pattern corresponding to the last address of the display data RAM (DDRAM). Since serial data is latched when the display data character pattern corresponding to the starting address enters the internal shift register, the HD66720 drives from the head display.

Table 3 Relationship between Character Codes and Character Patterns (ROM Code: A03)

Lower Bits \ Upper Bits	0000	0001	0010	0011	0100	0101	0110	0111	1000	1001	1010	1011	1100	1101	1110	1111
xxxx0000	CG RAM (1)	A	0	a	P	`	F	Q	E		-	9	E	o	P	
xxxx0001	CG RAM (2)	B	!	1	A	Q	a	9	U	e	.	7	f	G	a	q
xxxx0010	CG RAM (3)	a	"	2	B	R	b	r	e	E	「	イ	ツ	×	β	θ
xxxx0011	CG RAM (4)	i	#	3	C	S	c	s	à	ó	」	ウ	T	E	ε	∞
xxxx0100	CG RAM (5)	ó	\$	4	D	T	d	t	ä	ö	、	I	ト	ト	μ	Ω
xxxx0101	CG RAM (6)	ú	%	5	E	U	e	u	á	ó	・	オ	ナ	1	σ	Ü
xxxx0110	CG RAM (7)	ñ	&	6	F	V	f	v	â	ô	ヲ	カ	ニ	ヨ	ρ	Σ
xxxx0111	CG RAM (8)	ñ	'	7	G	W	g	w	ç	ù	フ	†	ヌ	ラ	9	π
xxxx1000	CG RAM (1)	g	(	8	H	X	h	x	é	ý	イ	ウ	*	リ	フ	又
xxxx1001	CG RAM (2)	g	)	9	I	Y	i	y	ë	ö	、	ケ	ル	ル	”	y
xxxx1010	CG RAM (3)	z	*	:	J	Z	j	z	è	ü	エ	コ	ン	ク	ジ	〒
xxxx1011	CG RAM (4)	「	+	;	K	[	k	<	i	ç	オ	サ	ヒ	ロ	*	ア
xxxx1100	CG RAM (5)	」	,	<	L	¥	l	l	ï	é	ト	シ	フ	フ	ç	ア
xxxx1101	CG RAM (6)	i	-	=	M	J	m	)	i	¥	ユ	ズ	、	ン	ト	÷
xxxx1110	CG RAM (7)	ø	.	>	N	^	n	÷	Ä	Å	ヨ	セ	ホ	、	ñ	
xxxx1111	CG RAM (8)	ø	/	?	O	_	o	÷	Ä	f	ッ	ソ	マ	”	ö	■

# HD66720

Table 4 Relationship between Character Codes and Character Patterns (ROM Code: A02)

Lower Bits \ Upper Bits	0000	0001	0010	0011	0100	0101	0110	0111	1000	1001	1010	1011	1100	1101	1110	1111
xxxx0000	CG RAM (1)															
xxxx0001	CG RAM (2)															
xxxx0010	CG RAM (3)															
xxxx0011	CG RAM (4)															
xxxx0100	CG RAM (5)															
xxxx0101	CG RAM (6)															
xxxx0110	CG RAM (7)															
xxxx0111	CG RAM (8)															
xxxx1000	CG RAM (1)															
xxxx1001	CG RAM (2)															
xxxx1010	CG RAM (3)															
xxxx1011	CG RAM (4)															
xxxx1100	CG RAM (5)															
xxxx1101	CG RAM (6)															
xxxx1110	CG RAM (7)															
xxxx1111	CG RAM (8)		<td></td> <td></td> <td></td> <td></td> <td></td> <td></td> <td></td> <td></td> <td></td> <td></td> <td></td> <td></td> <td></td>													

Note: The character codes of the characters enclosed in the bold frame are the same as those of the first edition of the ISO8859 and the character code compatible.

**Table 5 Relationships between CGRAM Address, Character Codes (DDRAM) and Character Patterns (CGRAM Data)**

**a) When character pattern is 5 × 8 dots**

Character code (DDRAM data)								CGRAM address						MSB	CGRAM data								LSB
D7	D6	D5	D4	D3	D2	D1	D0	A5	A4	A3	A2	A1	A0	O7	O6	O5	O4	O3	O2	O1	O0		
0	0	0	0	*	0	0	0	0	0	0	0	0	0	*	*	*	1	0	0	0	1	Character pattern (1)	
											0	0	1				1	0	0	0	1		
											0	1	0				1	0	0	0	1		
											0	1	1				0	1	0	1	0		
											1	0	0				0	0	1	0	0		
											1	0	1				0	0	1	0	0		
											1	1	0				0	0	1	0	0		
											1	1	1				0	0	0	0	0		
0	0	0	0	*	1	1	1	1	1	1	0	0	0	*	*	*	1	0	0	0	1	Character pattern (8)	
											0	0	1				1	0	0	0	1		
											0	1	0				1	0	0	0	1		
											0	1	1				0	1	0	1	0		
											1	0	0				0	0	1	0	0		
											1	0	1				0	0	1	0	0		
											1	1	0				0	0	1	0	0		
											1	1	1				0	0	0	0	0		

**a) When character pattern is 6 × 8 dots**

Character code (DDRAM data)								CGRAM address						MSB	CGRAM data								LSB
D7	D6	D5	D4	D3	D2	D1	D0	A5	A4	A3	A2	A1	A0	O7	O6	O5	O4	O3	O2	O1	O0		
0	0	0	0	*	0	0	0	0	0	0	0	0	0	*	*	0	1	0	0	0	1	Character pattern (1)	
											0	0	1				0	1	0	0	0		1
											0	1	0				0	1	0	0	0		1
											0	1	1				0	0	1	0	1		0
											1	0	0				0	0	0	1	0		0
											1	0	1				0	0	0	1	0		0
											1	1	0				0	0	0	1	0		0
											1	1	1				0	0	0	0	0		0
0	0	0	0	*	1	1	1	1	1	1	0	0	0	*	*	0	1	0	0	0	1	Character pattern (8)	
											0	0	1				0	1	0	0	0		1
											0	1	0				0	1	0	0	0		1
											0	1	1				0	0	1	0	1		0
											1	0	0				0	0	0	1	0		0
											1	0	1				0	0	0	1	0		0
											1	1	0				0	0	0	1	0		0
											1	1	1				0	0	0	0	0		0

---

## HD66720

---

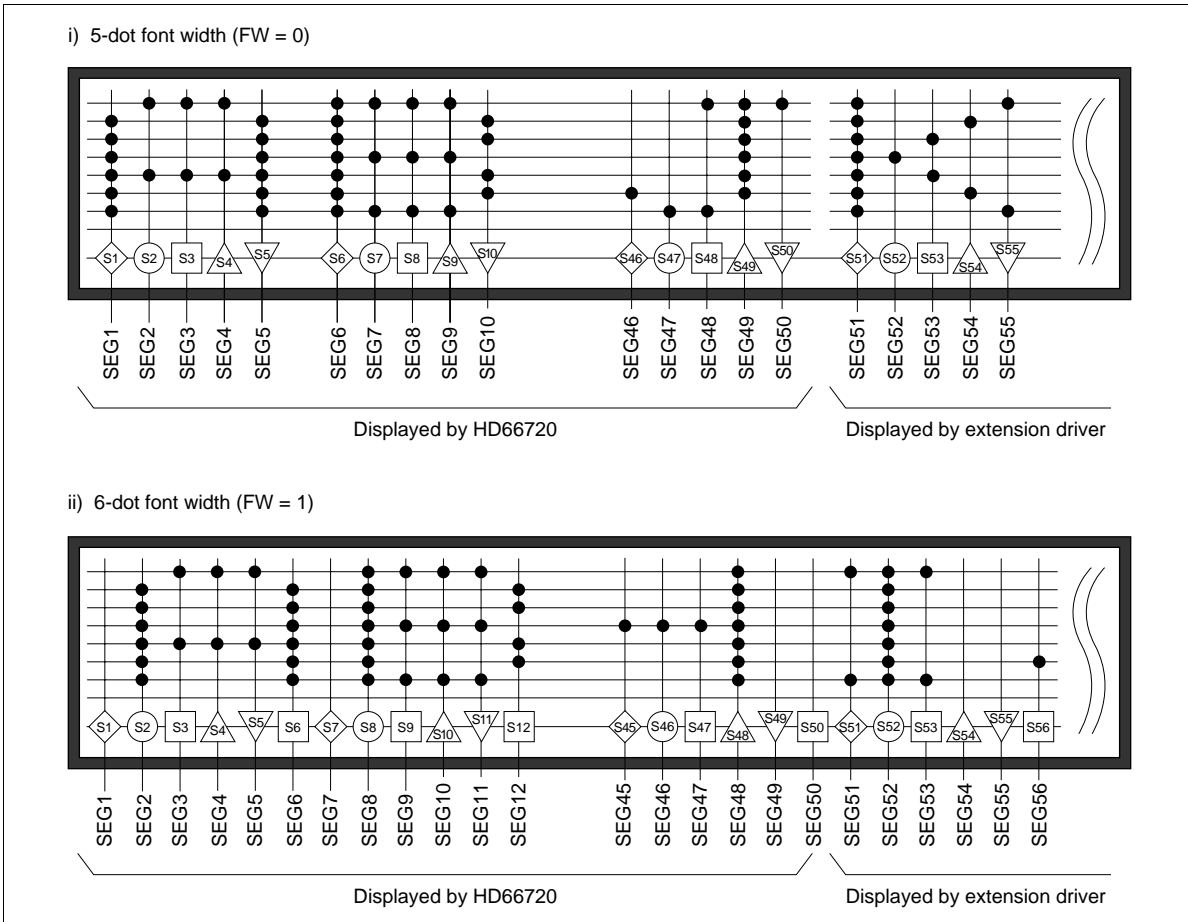
- Notes:
1. Character code bits 0 to 2 correspond to CGRAM address bits 3 to 5 (3 bits: 8 types).
  2. CGRAM address bits 0 to 2 designate the character pattern line position. The 8th line is the cursor position and its display is formed by a logical OR with the cursor.
  3. The character data is stored with the rightmost character element in bit 0, as shown in the figure above. Characters of 5 dots in width (FW = 0) are stored in bits 0 to 4, and characters of 6 dots in width (FW = 1) are stored in bits 0 to 5.
  4. When the upper four bits (bits 7 to 4) of the character code are 0, CGRAM is selected. Bit 3 of the character code is invalid (\*). Therefore, for example, the character codes (00)H and (08)H correspond to the same CGRAM address.
  5. A set bit in the CGRAM data corresponds to display selection, and 0 to non-selection.
  6. When the BE bit of the function set register is 1, pattern blinking control of the lower six bits is controlled using the upper two bits (bits 7 and 6) in CGRAM. When bit 7 is 1, of the lower six bits, only those which are set are blinked on the display. When bit 6 is 1, a bit 4 pattern can be blinked as for a 5-dot font width, and a bit 5 pattern can be blinked as for a 6-dot font width.

**Table 6 Relationship between SEGRAM Addresses and Display Patterns**

SEGRAM address				SEGRAM data															
				a) 5-dot font width								b) 6-dot font width							
A3	A2	A1	A0	D7	D6	D5	D4	D3	D2	D1	D0	D7	D6	D5	D4	D3	D2	D1	D0
0	0	0	0	B1	B0	*	S1	S2	S3	S4	S5	B1	B0	S1	S2	S3	S4	S5	S6
0	0	0	1	B1	B0	*	S6	S7	S8	S9	S10	B1	B0	S7	S8	S9	S10	S11	S12
0	0	1	0	B1	B0	*	S11	S12	S13	S14	S15	B1	B0	S13	S14	S15	S16	S17	S18
0	0	1	1	B1	B0	*	S16	S17	S18	S19	S20	B1	B0	S19	S20	S21	S22	S23	S24
0	1	0	0	B1	B0	*	S21	S22	S23	S24	S25	B1	B0	S25	S26	S27	S28	S29	S30
0	1	0	1	B1	B0	*	S26	S27	S28	S29	S30	B1	B0	S31	S32	S33	S34	S35	S36
0	1	1	0	B1	B0	*	S31	S32	S33	S34	S35	B1	B0	S37	S38	S39	S40	S41	S42
0	1	1	1	B1	B0	*	S36	S37	S38	S39	S40	B1	B0	S43	S44	S45	S46	S47	S48
1	0	0	0	B1	B0	*	S41	S42	S43	S44	S45	B1	B0	S49	S50	S51	S52	S53	S54
1	0	0	1	B1	B0	*	S46	S47	S48	S49	S50	B1	B0	S55	S56	S57	S58	S59	S60
1	0	1	0	B1	B0	*	S51	S52	S53	S54	S55	B1	B0	S61	S62	S63	S64	S65	S66
1	0	1	1	B1	B0	*	S56	S58	S58	S59	S60	B1	B0	S67	S68	S69	S70	S71	S72
1	1	0	0	B1	B0	*	S61	S62	S63	S64	S65	B1	B0	S73	S74	S75	S76	S77	S78
1	1	0	1	B1	B0	*	S66	S67	S68	S69	S70	B1	B0	S79	S80	S81	S82	S83	S84
1	1	1	0	B1	B0	*	S71	S72	S73	S74	S75	B1	B0	S85	S86	S87	S88	S89	S90
1	1	1	1	B1	B0	*	S76	S77	S78	S79	S80	B1	B0	S91	S92	S93	S94	S95	S96

Blinking control
Pattern on/off
Blinking control
Pattern on/off

- Notes:
1. Data set to SEGRAM is output when COMS is selected.
  2. S1 to S96 are pin numbers of the segment output driver. S1 is positioned to the left of the display. When the HD66720 is used by one chip, segments from S1 to S50 and S1 to S42 are displayed for a 1-line display and a 2-line display, respectively. An extension driver displays the segments after S50 and S42.
  3. After S80 output at 5-dot font and S96 output at 6-dot font, S1 output is repeated again.
  4. As for a 5-dot font width, lower five bits (D4 to D0) are display on/off information of each segment. For a 6-dot character width, the lower six bits (D5 to D0) are the display information for each segment.
  5. When the BE bit of the function set register is 1, pattern blinking of the lower six bits is controlled using the upper two bits (bits 7 and 6) in SEGRAM. When bit 7 is 1, only a bit set to 1 of the lower six bits is blinked on the display. When bit 6 is 1, only a bit 4 pattern can be blinked as for a 5-dot font width, and only a bit 5 pattern can be blinked as for 6-dot font width.
  6. Bit 5 (D5) is invalid for a 5-dot font width.
  7. Set bits in the SEGRAM data correspond to display selection, and zeros to non-selection.



**Figure 8 Correspondence between SEGRAM and Segment Display**

- **Cursor/Blink Control Circuit**

The cursor/blink (or white-black inversion) control is used to produce a cursor or a flashing area on the display at a position corresponding to the location in stored in the address counter (AC).

For example (Figure 9), when the address counter is (08)H, a cursor is displayed at a position corresponding to DDRAM address (08)H.

Note: Cursor/blink/black and white inversion is performed even when the address counter (AC) is selecting CGRAM or SEGRAM. However, in that case, cursor/blink/black and white inversion does not have any meaning.

- **Scroll Control Circuit**

The scroll control circuit is used to perform a smooth-scroll in units of dots. When the number of characters to be displayed is greater than that possible at one time on the liquid crystal module, this horizontal smooth scroll can be used to display all characters. Since display lines to scroll can be specified by the register function, random lines can only be scrolled in 2-line mode. Refer to Horizontal Dot Scroll, for details.

- **LED Output Control**

The HD66720 has two register-controlled general-purpose output ports. Like other registers, these ports can be set by the MPU via a serial interface to control LED illumination, so there is no need for special control signals.

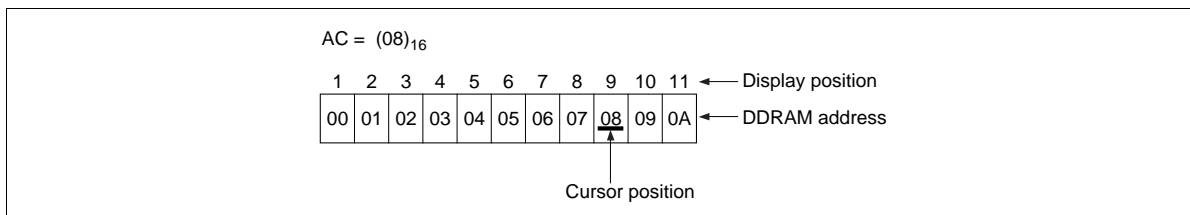
### Oscillator

The HD66720 has a built-in R-C oscillator that can be operated with the addition of a single external resistor. Since this resistor is externally mounted, it can be adjusted to produce the required frequency. Note that changing the operating frequency will effect the frame refresh frequency, the blink rates of the cursors, segments and characters, and the key scan frequency.

The system can also be synchronized with other equipment by inputting an external clock.

### LCD Booster Circuit

The LCD booster circuit produces a drive voltage for the LCD by boosting the standard supply voltage by two or three times. All that is needed to operate this circuit is either two or three (depending on the boost factor) external capacitors of about 1  $\mu$ F each. When driving a large LCD that draws a high load current, there will be an excessive voltage drop at the output of the booster—if this occurs, please use an external LCD power supply.



**Figure 9 Cursor/Blink Display Example**

## **Modifying Character Patterns**

### **Character Pattern Development Procedure**

The following operations correspond to the numbers listed in Figure 10:

1. Determine the correspondence between character codes and character patterns.
2. Create a listing indicating the correspondence between EPROM addresses and data.
3. Program the character patterns into an EPROM.
4. Send the EPROM to Hitachi.
5. Computer processing of the EPROM is performed at Hitachi to create a character pattern listing, which is sent to the user.
6. If there are no problems within the character pattern listing, a trial LSI is created at Hitachi and samples are sent to the user for evaluation. When it is confirmed by the user that the character patterns are correctly written, mass production of the LSI will proceed at Hitachi.

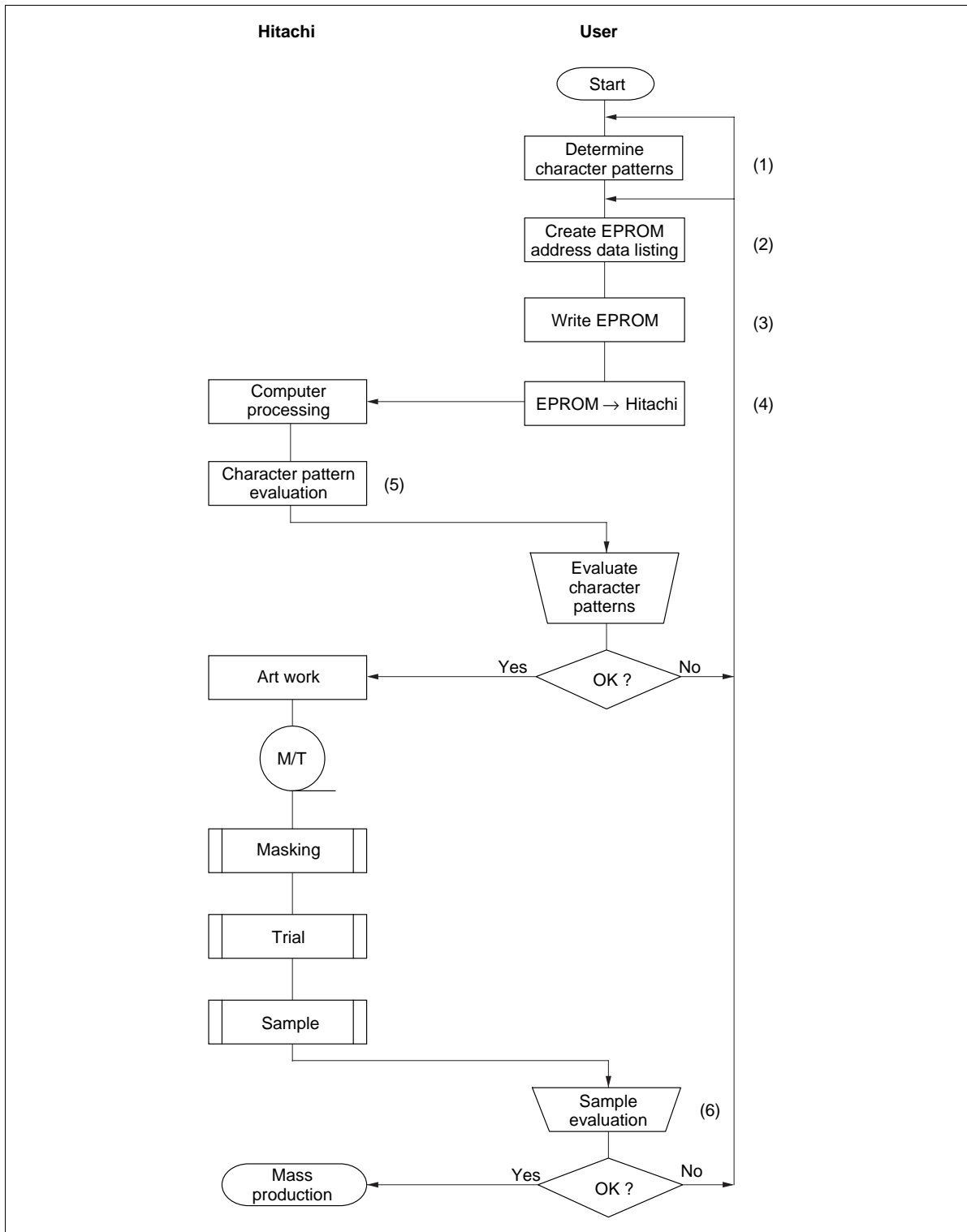


Figure 10 Character Pattern Development Procedure

# HD66720

## Programming Character Patterns

This section explains the correspondence between addresses and data used to program character patterns in EPROM.

- Programming to EPROM
 

The HD66720 character generator ROM can generate 240  $5 \times 8$  dot character patterns. Table 7 shows correspondence between the EPROM address, data, and the character pattern.
- Handling unused character patterns
  1. **EPROM data outside the character pattern area:** This is ignored and so any data is acceptable because it does not affect display operation using the character generator ROM.
  2. **EPROM data in CGRAM area:** Always fill with zeros.
  3. **Treatment of unused user patterns in the HD66720 EPROM:** According to the user application, these are handled in either of two ways:
    - a. **When unused character patterns are not programmed:** If an unused character code is written into DDRAM, all its dots are lit, because the EPROM is filled with 1s after it is erased.
    - b. **When unused character patterns are programmed as 0s:** Nothing is displayed even if unused character codes are written into DDRAM. (This is equivalent to a space.)

**Table 7 Correspondence Example between EPROM Address**

EPROM Address										Data						
A11	A10	A9	A8	A7	A6	A5	A4	A3	A2	A1	A0	MSB	Data			LSB
										O4	O3	O2	O1	O0		
0	1	0	1	1	0	0	1	0	0	0	0	1	0	0	0	1
								0	0	0	1	1	0	0	0	1
								0	0	1	0	1	0	0	0	1
								0	0	1	1	0	1	0	1	0
								0	1	0	0	0	0	1	0	0
								0	1	0	1	0	0	1	0	0
								0	1	1	0	0	0	1	0	0
								0	1	1	1	0	0	0	0	0

Character code
0
Line position

- Notes:
1. EPROM addresses A11 to A4 correspond to a character code.
  2. EPROM addresses A2 to A0 specify the line position of the character pattern. EPROM address A3 should be set to 0.
  3. EPROM data O4 to O0 correspond to character pattern data.
  4. Areas which are lit (indicated by shading) are stored as 1, and unlit areas as 0.
  5. The eighth line is also stored in the CGROM, and should also be programmed. If the eighth line is used for a cursor, this data should all be set to zero.
  6. EPROM data bits O7 to O5 are invalid. 0 should be written in all bits.

## **Instructions**

### **Outline**

Only the instruction register (IR) and the data register (DR) of the HD66720 can be controlled by the MPU. Before starting internal operation of the HD66720, control information is temporarily stored in these registers to allow interfacing with various MPUs, which operate at different speeds, or various peripheral control devices. The internal operation of the HD66720 is determined by signals sent from the MPU. These signals, which include register selection bit (RS), read/write bits (R/W), and the data bus bits (DB0 to DB7), make up the HD66720 instructions (Table 12). There are four categories of instructions that:

- Designate HD66720 functions, such as display format, data length, etc.
- Set internal RAM addresses
- Perform data transfer with internal RAM
- Perform miscellaneous functions

Normally, instructions that perform data transfer with internal RAM are used the most. However, auto-incrementation by 1 (or auto-decrementation by 1) of internal HD66720 RAM addresses after each data write can lighten the program load of the MPU. Since the display shift instruction can perform concurrently with display data write, the user can minimize system efficiently.

When an instruction is being executed for internal operation (BF = 1), no instruction other than the busy flag/scan data instruction can be executed.

Adjust the transmission rate so that the last bit of the next instruction is transmitted after executing the current instruction. Refer to Table 12 Instruction for instruction execution times. The execution times depend on the operation frequency (oscillation frequency). When using the R-C oscillator, be careful when determining the transmission rate, because it will vary greatly by the power supply voltage, operating temperature, and manufacturing tolerances.

---

## HD66720

---

### Instruction Description

#### Clear Display

Clear display writes space code (20)H (character pattern for character code (20)H must be a blank pattern) into all DDRAM addresses. It then sets DDRAM address 0 into the address counter, and returns the display to its original status if it was shifted. In other words, the display disappears and the cursor or blinking goes to the left edge of the display (in the first line if 2 lines are displayed). It also sets I/D to 1 (increment mode) in entry mode. S of entry mode does not change.

#### Return Home

Return home sets DDRAM address 0 into the address counter, and returns the display to its original status if it was shifted. The DDRAM contents do not change.

The cursor or blinking goes to the left edge of the display (in the first line if 2 lines are displayed).

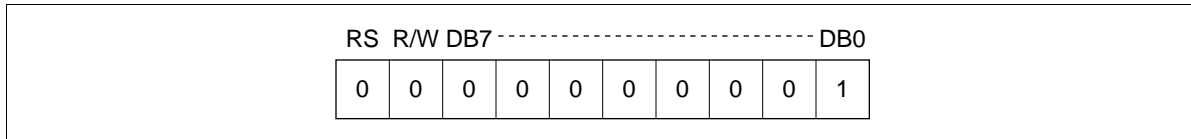
#### Entry Mode Set

**I/D:** Increments (I/D = 1) or decrements (I/D = 0) the DDRAM address by 1 when a character code is written into or read from DDRAM.

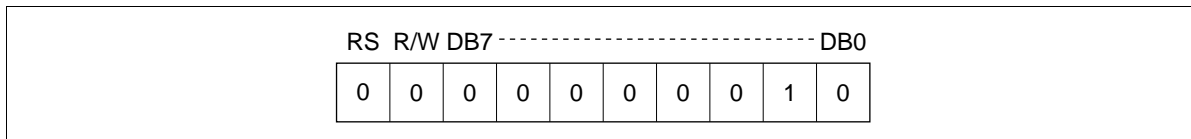
The cursor or blinking moves to the right when incremented by 1 and to the left when decremented by 1. The same applies to writing and reading of CGRAM and SEGRAM.

**S:** Shifts the entire display either to the right (I/D = 0) or to the left (I/D = 1) when S is 1 during DDRAM write. The display does not shift if S is 0.

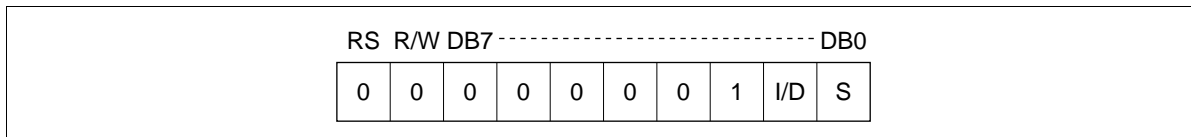
If S is 1, it will seem as if the cursor does not move but the display does. The display does not shift when reading from DDRAM. Also, writing into or reading out from CGRAM and SEGRAM does not shift the display. If S is 0, the display does not shift.



**Figure 11 Clear Display Instruction**



**Figure 12 Return Home Instruction**



**Figure 13 Entry Mode Set Instruction**

---

## HD66720

---

### Display On/Off Control

When extension register enable bit (RE) is 0, bits D, C, and B are accessed.

**D:** The display is on when D is 1 and off when D is 0. When off, the display data remains in DDRAM, and can be displayed instantly by setting D to 1.

**C:** The cursor is displayed when C is 1 and not displayed when C is 0. Even if the cursor disappears, the function of I/D or other specifications will not change during display data write. The cursor is displayed using 5 dots in the 8th line for  $5 \times 8$  dot character font.

**B:** The character indicated by the cursor blinks when B is 1. The blinking is displayed as switching between all blank dots and displayed characters at a speed of 340-ms intervals when  $f_{osc}$  is 160 kHz with a 5 dot font width. The cursor and blinking can be set to display simultaneously. (The blinking frequency changes according to the reciprocal of either  $f_{cp}$  or  $f_{osc}$ . For example, when  $f_{cp}$  is 120 kHz,  $340 \times 160/120 = 453$  ms.)

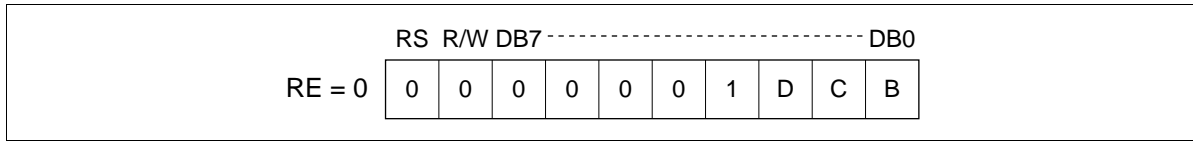
### Extension Function Set

When the extended register enable bit (RE) is 1, FW, FR, and B/W bits shown are accessed. Once these registers are accessed, the set values are held even if the RE bit is set to zero.

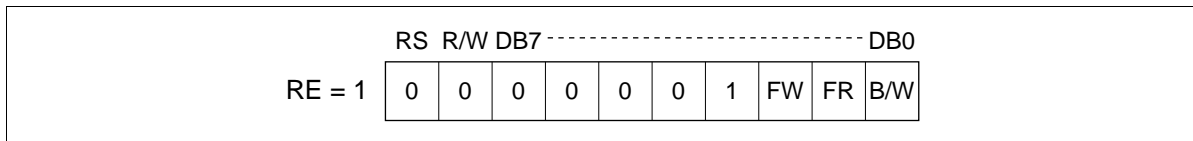
**FW:** When FW is 1, each displayed character is controlled with a 6-dot width. The user font in CGRAM is displayed with a 6-bit character width from bits 5 to 0. As for fonts stored in CGROM, no display area is assigned to the rightmost bit, and the font is displayed with a 5-dot character width. If the FW bit is changed, data in DDRAM and CGRAM is destroyed. Therefore, set FW before data is written to RAM. When font width is set to 6 dots, the frame frequency decreases to  $5/6$  compared to 5-dot time. See Oscillator for details. FW can only be set at the head of a program before any other instructions (except for Read Busy Flag & Scan Data). If the value of bit FW is modified after executing other instruction, the data in RAM may be damaged.

**FR:** When FR is 1, the display data stored in CGROM/CGRAM/SEGRAM is reflected horizontally. Select FR according to how the LSI is mounted. The display location of each character does not change.

**B/W:** When B/W is 1, the character at the cursor position is cyclically displayed with black-white inversion. At this time, bits C and B in display on/off control register are “Don’t care”. When  $f_{cp}$  or  $f_{osc}$  is 160 kHz, display is changed by switching every 360 ms.



**Figure 14 Display On/Off Control Instruction**



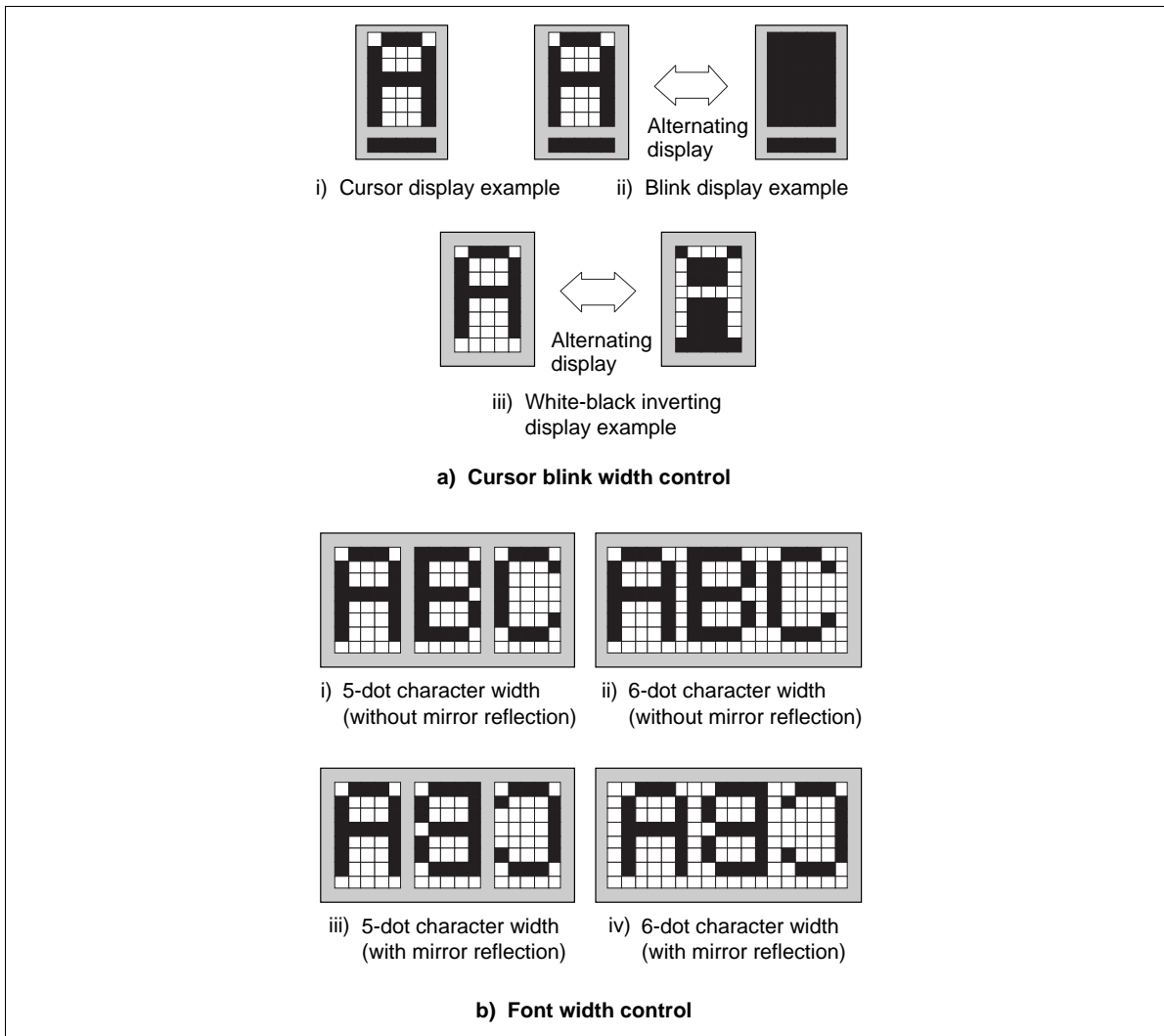
**Figure 15 Extended Function Set Instruction**

**Cursor or Display Shift**

Only when the extended register bit (RE) is 0, the S/C and R/L bits can be set.

**S/C, R/L:** Cursor or display shift shifts the cursor position or display to the right or left without writing or reading display data (Table 8). This function is used to correct or search the display. In a 2-line display, the cursor moves to the second line when it passes the 20th digit of the first line.

Note that, all line displays will shift at the same time. When the displayed data is shifted repeatedly each line moves only horizontally. The second line display does not shift into the first line position. When this instruction is executed, extended register enable bit (RE) is reset. The address counter (AC) contents will not change if only a display shift is performed.



**Figure 16 Example of Display Control**

**Scroll/LED Control**

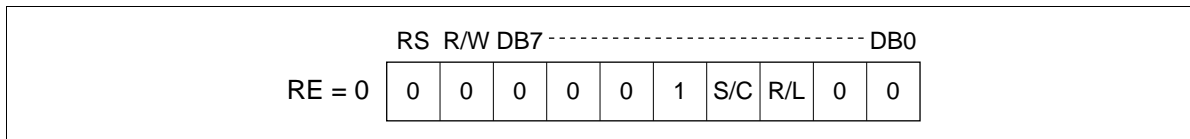
Only when the extended register bit (RE) is 1, the LED and HSE bits can be set.

**LED:** This bit controls the LEDs. The data set in bits LED0 and LED1 is reversed and output from pins LED0 and LED1. In other words, if 1 is set in bit LED0, a low level is output from pin LED0. This register function can also be used as a general output port instead of LED control.

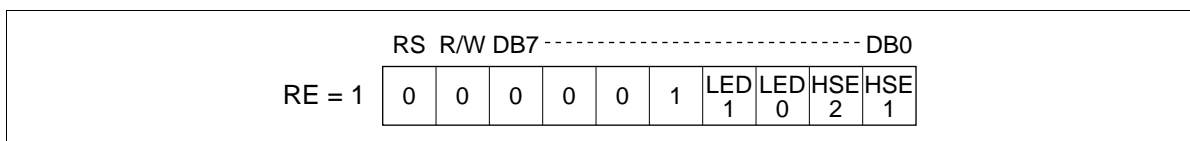
**HSE:** This bit specifies which display line or lines are to be dot shifted by the amount indicated in the set scroll quantity register. When HSE is 1 the first line scrolls and when HSE2 is 1 the second line scrolls.

**Table 8 Cursor or Display Shift Function**

S/C	R/L	Description
0	0	Shifts the cursor position to the left (AC is decremented by one)
0	1	Shifts the cursor position to the right (AC is incremented by one)
1	0	Shifts the entire display to the left. The cursor follows the display shift.
1	1	Shifts the entire display to the right. The cursor follows the display shift.



**Figure 17 Cursor of Display Shift Instruction**



**Figure 18 Scroll/LED Control Instruction**

---

## HD66720

---

### Function Set

Only when the extended register enable bit (RE) is 0, the KF bit can be accessed, and only when 1, the BE and the LP bits can be accessed. Bits IRE and SLP can be accessed regardless of RE.

**IRE:** When bit IRE is 1, key scan interrupts are generated. When a key is pressed, pin IRQ becomes low level.

**SLP:** When SLP is 1, the LSI enters sleep mode. During sleep mode, the display is disabled because the internal operation clock is divided by 16. However, the key scan cycle is not affected. For details, refer to Sleep Mode. In this mode, the frame frequency is also divided by 16.

**RE:** When bit RE is 1, extension function set register, scroll/LED control register, set scroll quantity register, the set SEGRAM address register, and bit BE in the function set register, can be accessed. When bit RE is 0, the registers described above cannot be accessed, and the data in these registers is held.

**KF:** When RE is 0, these bits specify the key scan cycle. Set these bits according to the mechanical characteristic of the keys. The key scan cycles relies on the operation cycles(oscillation frequency). Table 10 shows the key scan cycles for the case when the operation frequency (oscillation frequency) is 160 kHz.

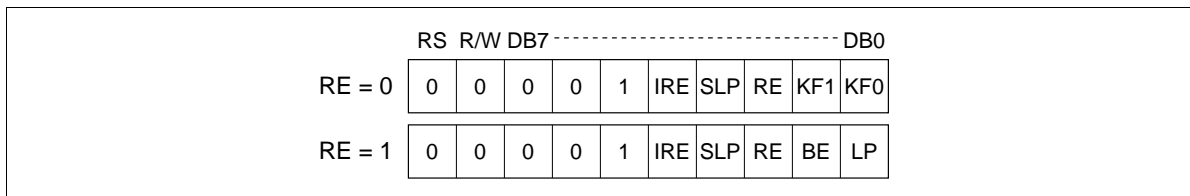
**BE:** When bit RE is 1, this bit can be rewritten. When this bit is 1, the user font in CGRAM and the segment in SEGRAM can be blinked according to the upper two bits of CGRAM and SEGRAM.

**LP:** When bit RE is 1, this bit can be rewritten. When LP is set to 1, the HD66720 operates in low power mode. In 1-line display mode, the HD66720 operates by dividing the oscillation frequency by four, and in a 2-line display mode, the HD66720 operates at the oscillation frequency divided by two. Thus, 10 characters at the most are displayed in one line. According to these operations, instruction execution takes four times or twice as long. When performing display shift and smooth scroll during low power mode, the resulting display will differ from the normal mode display (refer to Low Power Mode for details).

**Table 9 Key Scan Cycle**

<b>KF1</b>	<b>KF0</b>	<b>Key Scan Cycle</b>
0	0	9.6 ms (1536 Tc)
0	1	4.8 ms (768 Tc)
1	0	19.2 ms (3072 Tc)
1	1	38.4 ms (6144 Tc)

\*: For the case when  $f_{cp}(f_{osc})$  is 160 kHz.  $Tc = 1/f_{cp}(f_{osc})$



**Figure 19 Function Set Instruction**

---

## HD66720

---

### Set CGRAM Address

A CGRAM address can be set while the RE bit is cleared to 0.

Set CGRAM address sets the address indicated by binary AAAAAA into the address counter. After this address set, CGRAM can be written to or read from by the MPU.

### Set SEGRAM Address

Only when the extended register enable (RE) bit is 1, the SEGRAM address can be set.

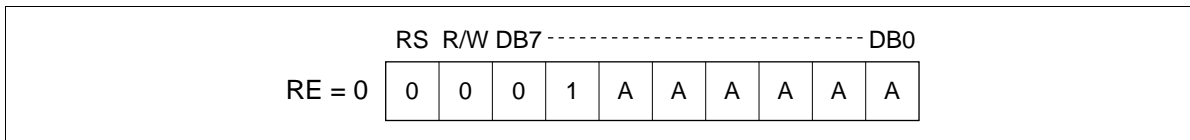
The SEGRAM address in the binary form AAAA is set to the address counter. After this address set, SEGRAM can be written to or read from by the MPU.

### Set DDRAM Address

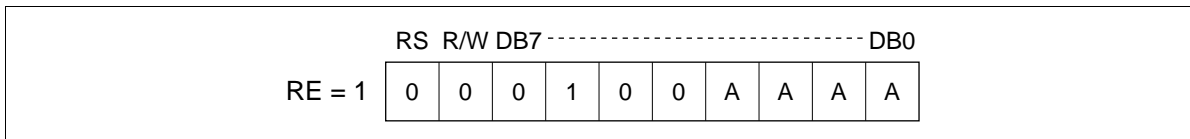
A DDRAM address can be set while the RE bit is cleared to 0.

Set DDRAM address sets the DDRAM address binary indicated by AAAAAA into the address counter. After this address set, DDRAM can be written to or read from by the MPU.

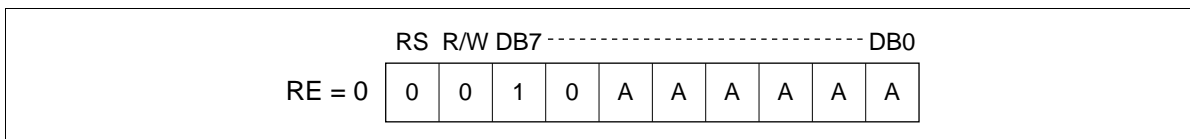
When NL is low (1-line display), AAAAAA can be H(00) to H(27). When NL is high (2-line display), AAAAAA can be H(00) to H(13) for the first line, and H(20) to H(33) for the second line.



**Figure 20 Set CGRAM Address Instruction**



**Figure 21 Set SEGRAM Address Instruction**



**Figure 22 Set DDRAM Address Instruction**

**Set Scroll Quantity**

When extended register enable bit (RE) is 1, PS 1/0 and HDS4 to HDS0 can be set.

**PS:** PS1 and PS0 specify the number of characters at the left side of the display that are unaffected by horizontal scrolls and are left intact while the rest of the display is scrolled (Table 10).

**HDS:** HDS4 to HDS0 specify horizontal scroll quantity to the left of the display in dot units. The HD66720 uses the unused DDRAM area to execute a desired horizontal smooth scroll from 1 to 24 dots (Table 11).

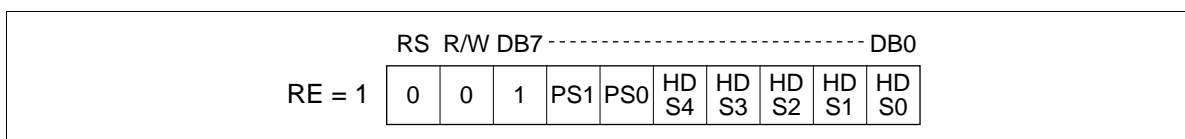
Note: When performing a horizontal scroll as described above by connecting an extension driver, the maximum number of characters per line decreases by the quantity corresponding to the specified scroll distance.

**Table 10 Partial Smooth Scroll**

PS1	PS0	Description
0	0	Fixes all characters
0	1	Fixes leftmost character in smooth scroll
1	0	Fixes the two leftmost characters in smooth scroll
1	1	Fixes the three leftmost characters in smooth scroll

**Table 11 Smooth Scroll Quantity**

HDS4	HDS3	HDS2	HDS1	HDS0	Description
0	0	0	0	0	No shift
0	0	0	0	1	Shifts the display position to the left by one dot
0	0	0	0	0	Shifts the display position to the left by two dots
0	0	0	1	1	Shifts the display position to the left by three dots
		•			
		•			
1	0	1	1	1	Shifts the display position to the left by 23 dots
1	*	*	*	*	Shifts the display position to the left by 24 dots



**Figure 23 Set Scroll Quantity Instruction**

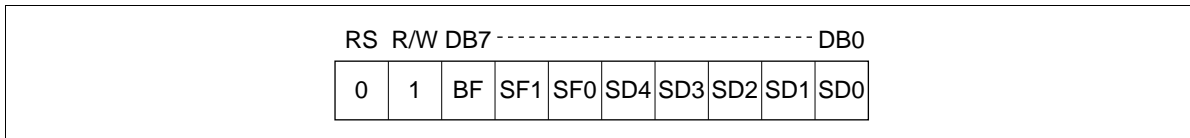
# HD66720

## Read Busy Flag & Scan Data

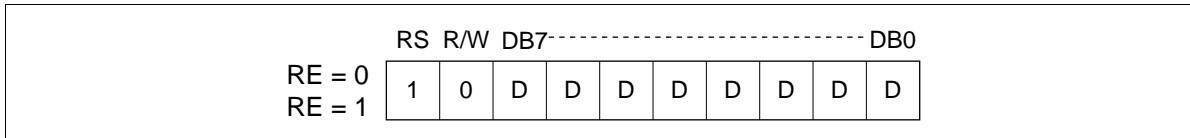
Scan data SD4 to SD0 latches into scan registers SCAN0 to SCAN5 and scan cycle state SF1 and SF0 is read sequentially. Refer to Key Scan Control for details. At the same time, busy flag (BF) is read. When BF is 1, the HD66720 is still processing an instruction already accepted, and does not accept another instruction until BF becomes 0. Adjust the transfer rate so that the HD66720 receives the last bit of the next instruction after BF has become 0.

## Write Data to CGRAM, DDRAM, or SEGRAM

This instruction writes 8-bit binary data DDDDDDDD to CGRAM, DDRAM or SEGRAM. CGRAM, DDRAM or SEGRAM is selected by the previous specification of the address set instruction (set CGRAM address/set DDRAM address/set SEGRAM address). After a write, the address is automatically incremented or decremented by 1 according to the entry mode. The entry mode also determines the display shift direction.



**Figure 24 Read Busy Flag & Scan Data Instruction**



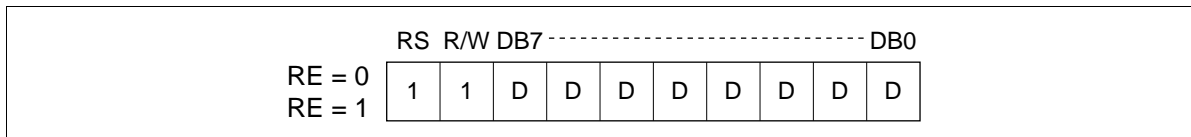
**Figure 25 Read Data from RAM Instruction**

**Read Data from CG, DD, or SEGRAM**

This instruction reads 8-bit binary data DDDDDDDD from CGRAM, DDRAM, or SEGRAM. CGRAM, DDRAM or SEGRAM is selected by the previous specification of the address set instruction. If no address is specified, the first data read will be invalid. When executing serial read instructions, data is normally read from the next address. An address set instruction need not be executed just before this read instruction when shifting the cursor by a cursor shift instruction (when reading from DDRAM). A cursor shift instruction is the same as a set DDRAM address instruction.

After a read, the entry mode automatically increases or decreases the address by 1. However, a display shift is not executed regardless of the entry mode.

Note: The address counter (AC) is automatically incremented or decremented after write instructions to CG, DD or SEGRAM. The RAM data selected by the AC cannot be read out at this time even if read instructions are executed. Therefore, to read data correctly, execute either an address set instruction or a cursor shift instruction (only with DDRAM), or alternatively, execute a preliminary read instruction to ensure the address is correctly set up before accessing the data.



**Figure 26 Read Data from RAM Instruction**

# HD66720

**Table 12 Instructions**

Instruction	RE	Code										Description	Execution Time (max) (when $f_{cp}$ or $f_{osc}$ is 160 kHz)	
	Bit	RS	R/W	DB7	DB6	DB5	DB4	DB3	DB2	DB1	DB0			
Clear display	0/1	0	0	0	0	0	0	0	0	0	0	1	Clears entire display and sets DDRAM address 0 in address counter	2.67 ms
Return home	0/1	0	0	0	0	0	0	0	0	0	1	0	Sets DDRAM address 0 in address counter. Also returns display from being shifted to original position. DDRAM contents remain unchanged.	2.67 ms
Entry mode set	0/1	0	0	0	0	0	0	0	0	1	I/D	S	Sets cursor move direction and specifies display shift. These operations are performed during data write and read.	63 $\mu$ s
Display on/off control	0	0	0	0	0	0	0	0	1	D	C	B	Sets entire display on/off (D), cursor on/off (C), and blinking of cursor position character (B).	63 $\mu$ s
Extension function set	1	0	0	0	0	0	0	0	1	FW	FR	B/W	Sets a font width (FW), font reverse (FR), and a black-white	63 $\mu$ s
Cursor or display shift	0	0	0	0	0	0	0	1	S/C	R/L	0	0	Moves cursor and shifts display without changing DDRAM contents.	63 $\mu$ s
Scroll/LED output control	1	0	0	0	0	0	0	1	LED1	LED0	HSE2	HSE1	Specifies which display lines to undergo horizontal smooth scroll and controls the output of LED.	63 $\mu$ s
Function set	0	0	0	0	0	0	1	IRE	SLP	RE	KF1	KF0	Set interrupt enable (IRE) sleep mode (SLP), extension register write enable (RE). Sets key scan cycle (KF) and extension register write enable.	63 $\mu$ s
	1	0	0	0	0	0	1	IRE	SLP	RE	BE	LP	Sets CGRAM/SEGRAM blinking enable (BE), and low-power mode (LP).	63 $\mu$ s
Set CGRAM address	0	0	0	0	0	1	ACG	ACG	ACG	ACG	ACG	ACG	Sets CGRAM address. CGRAM data is sent and received after this setting.	63 $\mu$ s
Set SEGRAM address	1	0	0	0	0	1	0	0	ASEG	ASEG	ASEG	ASEG	Sets SEGRAM address. SEGRAM data is sent and received after this setting.	63 $\mu$ s

Table 12 Instructions (cont)

Instruction	RE Bit	Code										Description	Execution Time (max) (when $f_{cp}$ or $f_{osc}$ is 160 kHz)
		RS	R/W	DB7	DB6	DB5	DB4	DB3	DB2	DB1	DB0		
Set DDRAM address	0	0	0	1	0	ADD	ADD	ADD	ADD	ADD	ADD	Sets DDRAM address. DDRAM data is sent and received after this setting.	63 $\mu$ s
Set scroll quantity	1	0	0	1	PS1	PS0	HDS4	HDS3	HDS2	HDS1	HDS0	Sets horizontal dot scroll quantity (HDS) and partial scroll characters (PS).	63 $\mu$ s
Read busy flag & scan data	0/1	0	1	BF	SF1	SF0	SD4	SD3	SD2	SD1	SD0	Reads busy flag (BF), data in scan register (SD), and scan state (SF).	0 $\mu$ s
Write data to RAM	0/1	1	0									Write data	Writes data into DDRAM, CGRAM, or SEGRAM. $t_{ADD} = 9.3 \mu\text{s}^*$
Read data from RAM	0/1	1	1									Read data	Reads data from DDRAM, CGRAM, or SEGRAM. $t_{ADD} = 9.3 \mu\text{s}^*$

I / D = 1: Increment	LP = 1: Low-power mode
I/D = 0: Decrement	BF = 1: Internally operating
S = 1: Accompanies display shift	BF = 0: Instructions acceptable
D = 1: Display on	DDRAM : Display data RAM
C = 1: Cursor on	ADD : DDRAM corresponding to cursor address
B = 1: Blink on	CGRAM : Character generator RAM
FW = 1: 6-dot font width	ACG : CGRAM address
FR = 1: Horizontal font reflection	SEGRAM: Segment RAM
B/W = 1: Black-white inverting cursor on	ASEG : Segment RAM address
S/C = 1: Display shift	HSE2-1 : Specifies horizontal scroll lines
S/C = 0: Cursor move	HDS4-0 : Horizontal dot scroll quantity
R/L = 1: Shift to the right	PS1-0 : Specifies partial scroll quantity
R/L = 0: Shift to the left	LED1-0 : LED control
IRE = 1: Interrupt (IRQ) generation enable	KF1-0 : Key scan cycle
SLP = 1: Sleep mode	SD4-0 : Key scan data
RE = 1: Extension register write enable	SF1-0 : Key scan state
BE = 1: CGRAM/SEGRAM blinking enable	

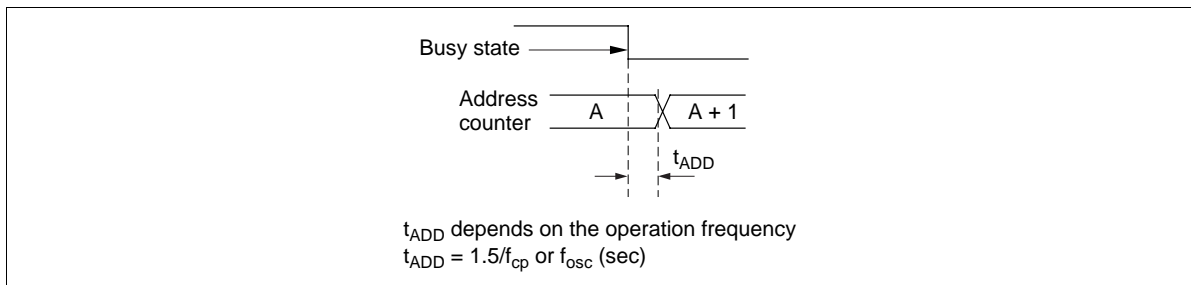


Figure 27  $t_{ADD}$  State

---

## HD66720

---

Note: 1. \*After execution of the CGRAM/DDRAM data write or read instruction, the RAM address counter is incremented or decremented by 1. The RAM address counter is updated after the busy flag is cleared.

$t_{ADD}$  is the time elapsed after the busy flag turns off until the address counter is updated.

2. The execution time mentioned above are for the case of 5-dot font. With a 6-dot font, it will take 20% more to execute an instruction. The execution time will also change if the frequency changes. For example, the execution time will be reduced to 80% when  $f$  is 200 kHz.

## **Reset Function**

### **Initializing by Internal Reset Circuit**

An internal reset circuit automatically initializes the HD66720 when the power is turned on. The following instructions are executed during the initialization. The busy flag (BF) is kept in the busy state until the initialization ends (BF = 1). The busy state lasts for 40 ms after  $V_{CC}$  rises to 4.5V or 80 ms after the  $V_{CC}$  rises to 2.7V.

1. Clear display  
(20)H to all DDRAM
2. Function set  
IRE = 0: Interrupt (IRQ) generation disable  
SLP = 0: Clear sleep mode  
RE = 0: Extension register write disable  
KF = 0: Key scan cycle 9.6 ms  
BE = 0: CGRAM/SEGRAM blinking off  
LP = 0: Not in low power mode
3. Display on/off control  
D = 0: Display off  
C = 0: Cursor off  
B = 0: Blinking off
4. Entry mode set  
I/D = 1: Increment by 1  
S = 0: No shift
5. Extension function set  
FR = 0: Without font reverse  
B/W = 0: Normal cursor (8th line)
6. Scroll/LED control  
HSE = 00: Scroll unable  
LED = 00: LED output level = high
7. Set scroll quantity  
HDS = 00000: Not scroll

Note: If the electrical characteristics conditions listed under the table Power Supply Conditions Using Internal Reset Circuit are not met, the internal reset circuit will not operate normally and will fail to initialize the HD66720.

---

## HD66720

---

### Initializing by Hardware Reset Input

The HD66720 also has a reset input pin (RESET\*). If this pin is made low during operation, an internal reset and initialization is performed except for key scan cycle setting bit (KF). A hardware reset can turn off display when the HD66720 is switched off. A reset input is ignored, however, during internal reset after power-on. In other words, the internal reset has priority. The level of the reset pin must always be pulled up to  $V_{CC}$  when the hardware reset input is not used.

### Transferring Serial Data

A three-line clock-synchronous transfer method is used. The HD66720 receives serial input data (SID) and transmits serial output data (SOD) by synchronizing with a transfer clock (SCLK) sent from the master side.

When the HD66720 interfaces with several chips, chip select pin (CS\*) must be used. The transfer clock (SCLK) input is activated by making chip select (CS\*) low. In addition, the transfer counter of the HD66720 can be reset and serial transfer synchronized by making chip select (CS\*) high. Here, since the data which was being sent at reset is cleared, restart the transfer from the first bit of this data. In a minimum system where a single HD66720 interfaces to a single MPU, an interface can be constructed from the transfer clock (SCLK) and serial data lines (SID and SOD). In this case, chip select (CS\*) should be fixed to low.

The transfer clock (SCLK) is independent from operational clock (CLK) of the HD66720. However, when several instructions are continuously transferred, the instruction execution time determined by the operational clock (CLK) (see continuous transfer) must be considered since the HD66720 does not have an internal transmit/receive buffer.

To begin with, transfer the start byte. By receiving five consecutive bits (synchronizing bit string) at the beginning of the start byte, the transfer counter of the HD66720 is reset and serial transfer is synchronized. The 2 bits following the synchronizing bit string (5 bits) specify transfer direction (R/W bit) and register select (RS bit). Be sure to transfer 0 in the 8th bit.

After receiving the start byte, instructions are received and the data/busy flag is transmitted. When the transfer direction and register select remain the same, data can be continuously transmitted or received.

The transfer protocol is described in detail in the following.

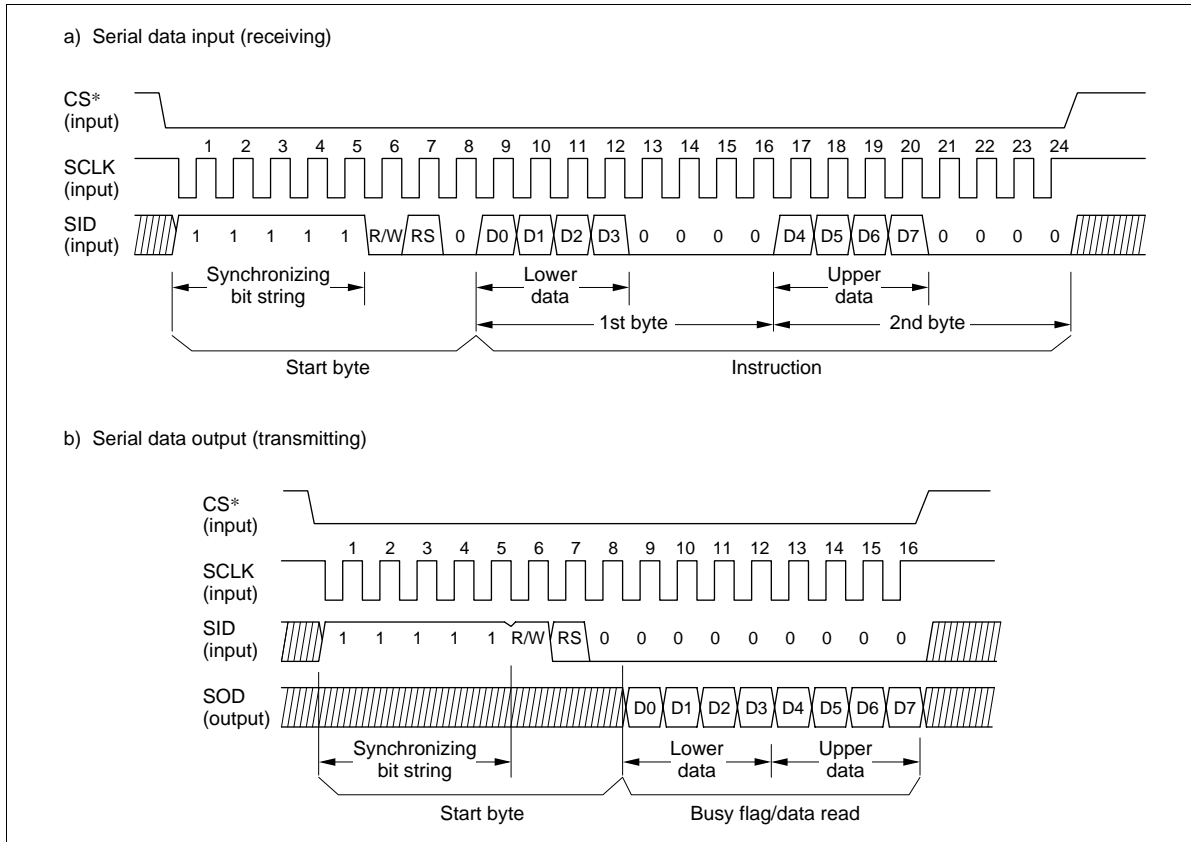


Figure 28 Basic Procedure for Transferring Serial Data

---

## HD66720

---

- Receiving (write)

After receiving the start synchronizing bit string, the R/W bit (= 0), and the RS bit in the start byte, an 8-bit instruction is received in 2 bytes: the lower 4 bits of the instruction are placed in the LSB of the first byte, and the higher 4 bits of the instruction are placed in the LSB of the second byte. Be sure to transfer 0 in the following 4 bits of each byte. When instructions are continuously received with R/W bit and RS bit unchanged, continuous transfer is possible (see Continuous Transfer in the following).

- Transmitting (read)

After receiving the synchronizing bit string, the R/W bit (= 0), and the RS bit with the start byte, 8-bit read data is transmitted from pin SOD in the same way as receiving. When read data is continuously transmitted with R/W bit and RS bit unchanged, continuous transfer is possible (see Continuous Transfer in the following).

If data is read when bit RS is set to 0, scan data latched into SCAN0 to SCAN5 registers is transmitted as the lower 5-bit data. After receiving the start byte, transmission starts from data in SCAN register latched at KST0 strobe. After transmitting data from the SCAN5 register, SCAN0 data is retransmitted. When reading RAM data with bit RS set to 1, it is necessary to wait for at least the duration of a RAM data read period.

During transmission (data output), the SID input is continuously monitored for a start synchronizing bit string (11111). Once this has been detected, the R/W and RS bits are received. Accordingly, 0 must always be input to SID when transmitting data continuously.

- Continuous Transfer

When instructions are continuously received with the R/W bit and RS bit unchanged, continuous receive is possible without inserting a start byte between instructions.

After receiving the last bit (the 8th bit in the 2nd byte) of an instruction, the system begins to execute it. To execute the next instruction, the instruction execution time of the HD66720 must be considered. If the last bit (the 8th bit in the 2nd byte) of the next instruction is received during execution of the previous instruction, the instruction will be ignored.

In addition, if the next unit of data is read before read execution of previous data is completed for busy flag/scan data/RAM data, normal data is not sent. To transfer data normally, the busy flag must be checked. However, it is possible to transfer without reading the busy flag if the burden of polling on the CPU needs to be removed. In this case, insert a transfer wait between instructions so that the current instruction first completes execution.

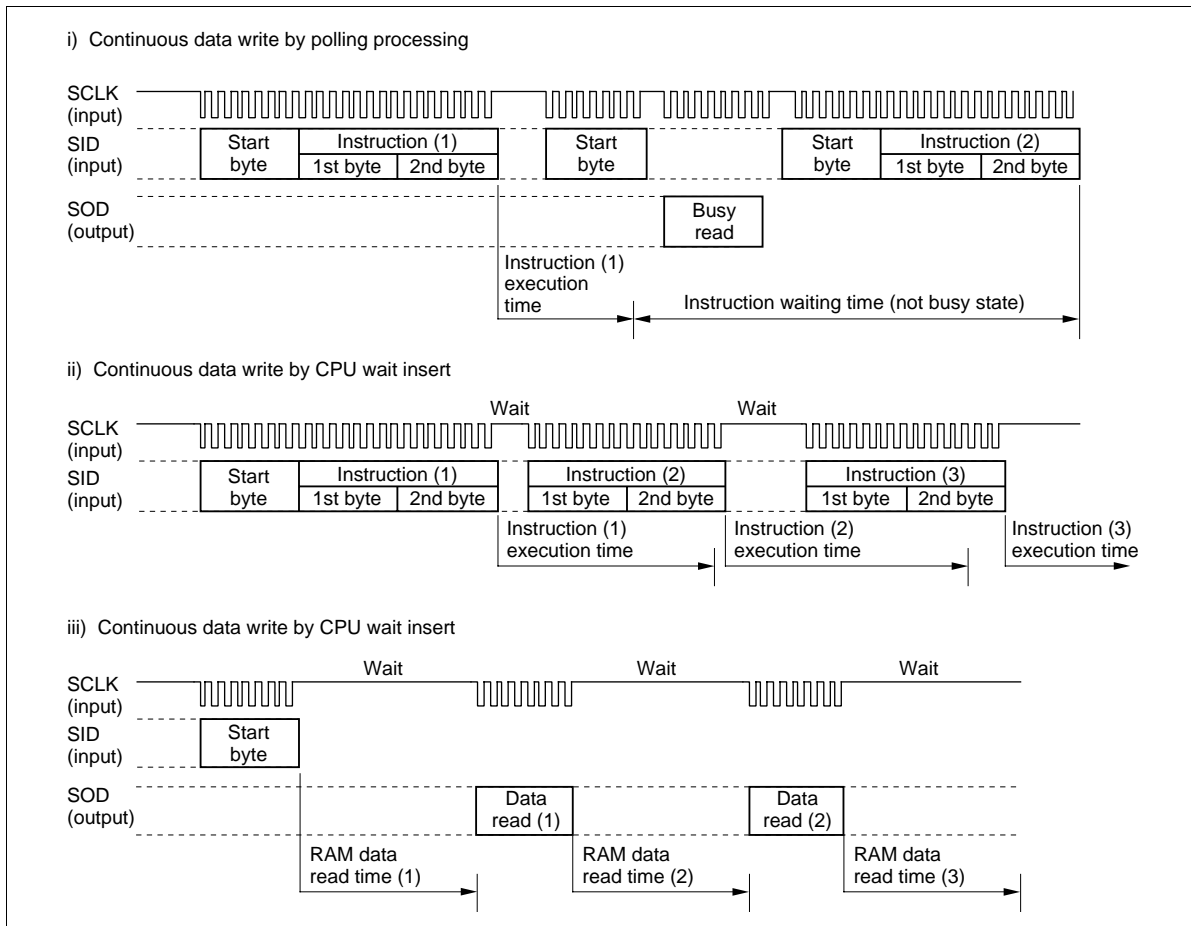


Figure 29 Procedure for Continuous Data Transfer

---

## HD66720

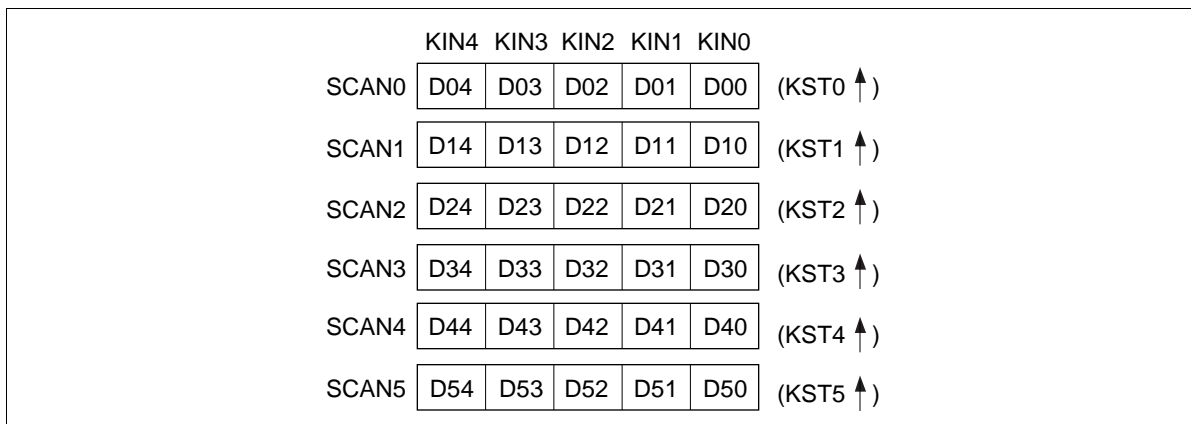
---

### Key Scan Control

The key matrix scanner senses the key states at each rising edge of the key strobe signals (KST) that are output by the HD66720. The key strobe signals are output as time-multiplexed signals from KST0 to KST4. After passing through the key matrix, these strobe signals are used to sample the key status on five inputs KIN0 to KIN4, enabling up to 30 keys to be scanned.

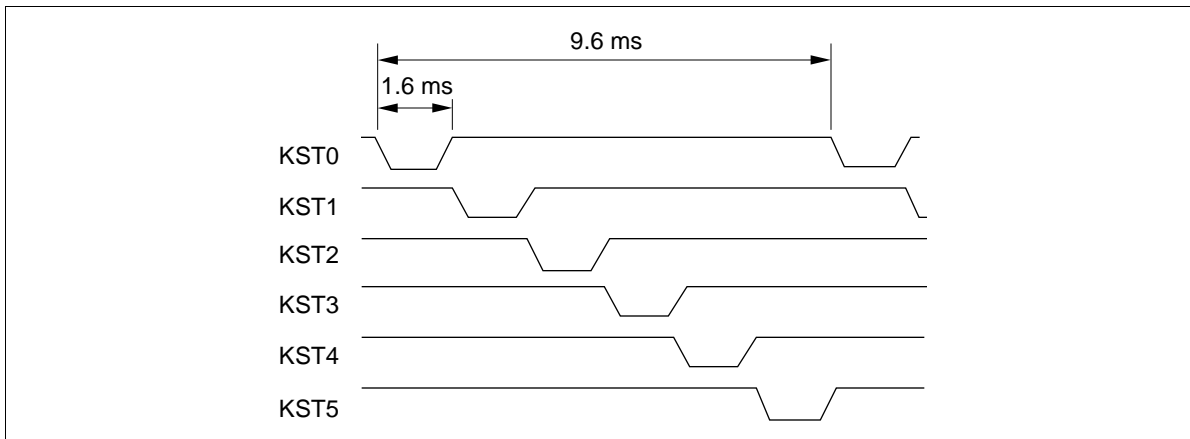
The states of inputs KIN0 to KIN4 are sampled by key strobe signal KST0 and latched into register SCAN0. Similarly, the data sampled by strobe signals KST1 to KST5 is latched into registers SCAN1 to SCAN5, respectively.

The generation cycle and pulse width of the key strobe signals depends on the operating frequency (oscillation frequency) of the HD66720 and the key scan cycle determined by KF0 and KF1. For example, when the operating frequency is 160 kHz and KF0 and KF1 are both 0, the generation cycle is 10 ms and the pulse width is 1.7 ms. When the operating frequency (oscillation frequency) is changed, the above generation cycle and the pulse width are also changed in inverse proportion.

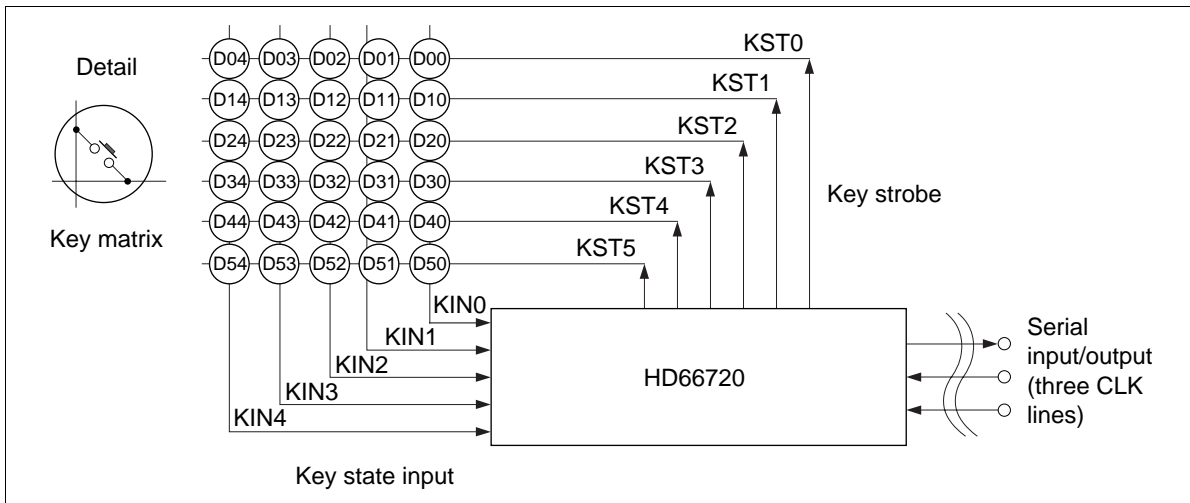


**Figure 30 Key Scan Register Configuration**

In order to compensate for the mechanical features of the keys, such as chattering and noise and for the key-strobe generation cycle and the pulse width, software should be used to ensure that the scanned data has been read two or three times in succession before it is assumed to be valid. Multiple keypress combinations should also be processed in software. Note that any multiple key combination is possible, however, if the key combination creates a cross pattern the scanned data will include unnecessary data. For example, if keys D12, D11, and D22 are pressed simultaneously, key D21 will also be pressed. The input pins KIN0 to KIN4 are pulled up to  $V_{CC}$  by MOS transistors (see Electrical Characteristics). External resistors may also be required to pull up the voltages further when the internal pull-ups are insufficient due to noise margins or other reasons.



**Figure 31 Key Strobe Output Timing (KF1/0 = 00,  $f_{cp}/f_{osc} = 160$  kHz)**



**Figure 32 Key Scan Configuration**

## HD66720

The key-scanned data is read via a three-line clock synchronous serial interface using the following procedure. First of all, a start byte is transferred. This must contain five bits of 1 (synchronizing bit string), a transfer direction bit (R/W) of 1, a register select bit (RS) of 1, and one bit of 0 in that order. The synchronizing bit string is used to reset the transfer counter of the HD66720, thus synchronizing the serial transfer.

After the HD66720 has received the above start byte, it reads scan data SD0 to SD4 from the SCAN0 register starting from the LSB. The HD66720 reads data from SCAN1, SCAN2, SCAN3, SCAN4, and SCAN5 in that order. After reading SCAN5, the HD66720 starts at SCAN0 again.

The HD66720 transfer counter can also be reset to synchronize serial transfer by driving the chip select (CS\*) high. In this case, the data currently transferred is cleared; therefore, transfer the start byte again to restart the transfer.

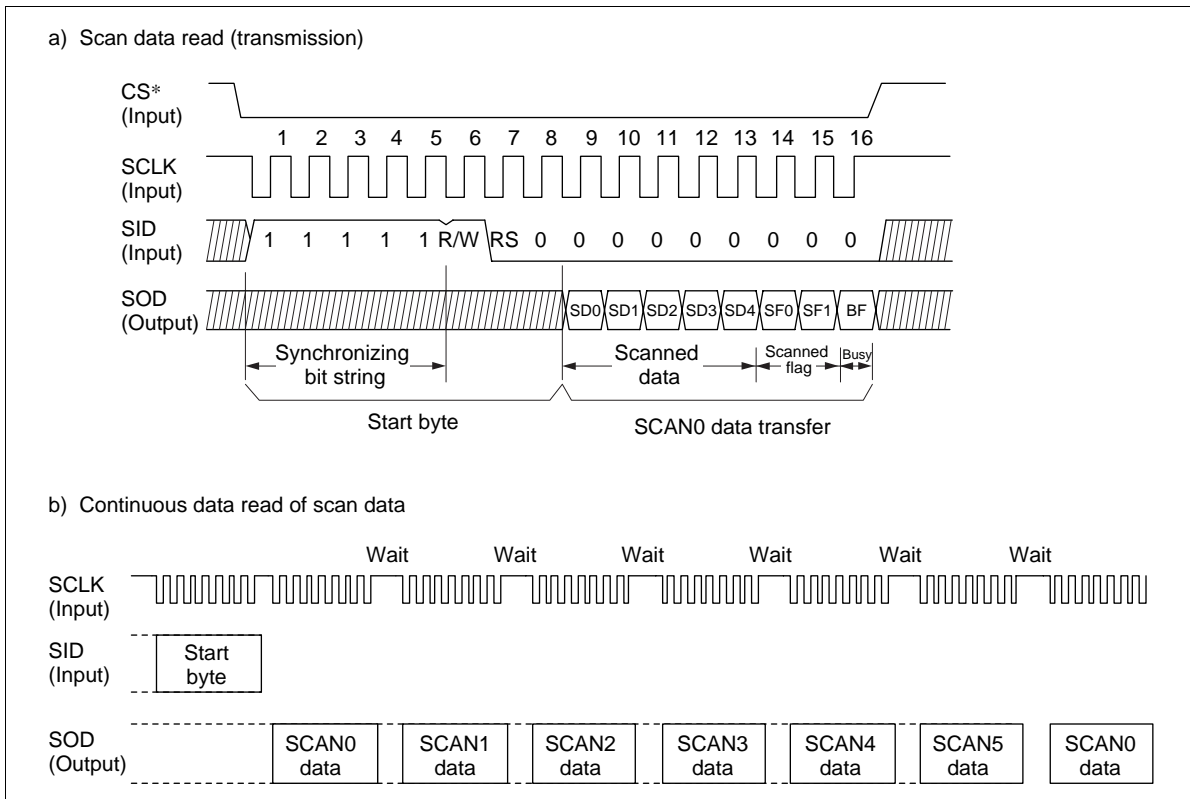


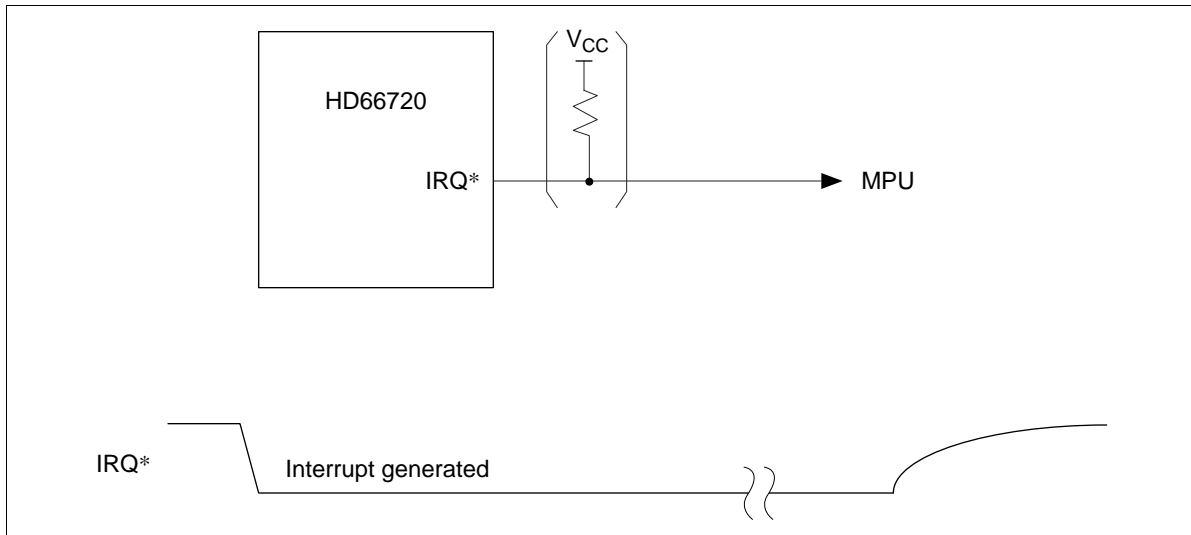
Figure 33 Scan Data Transfer

**Key Scan Interrupt (Wake-Up Function)**

If the MPU has set the interrupt enable bit (IRE) to 1, the LCD sends an interrupt signal to the MPU on detecting that a key has been pressed in the key scan circuit by setting the IRQ\* output pin to low level. An interrupt signal can be generated by pressing any key in a 30-key matrix. The interrupt level continues to be output during the key-scan cycle in which the key is being pushed.

Key scanning is performed and interrupts can occur during HD66720 sleep mode (SLP = "1"). The interrupt signal from HD66720 can trigger the MPU even though the whole system is in a sleep state (or standby state), thus, minimizing power consumption. The LCD cannot be displayed when the HD66720 is in sleep mode. Refer to Sleep Mode for details.

The output pin of IRQ\* is pulled up to the V<sub>CC</sub> with a MOS of 50 kΩ; however, pull up can be made stronger by adding external resistors as needed. Interrupts may occur if noise occurs in KIN input during key scanning. Interrupts maybe inhibited if not needed by setting the interrupt enable bit (IRE) to 0.



**Figure 34 Interrupt Generator**

# HD66720

## Extension Driver LSI Interface

The number of displayed characters can be increased by using an extension driver. For example, by adding a single extension driver with 40 LCD driver output, a 2-line 16 character display with a 5-dot font width can be achieved. Moreover, a maximum 2-line 20 character or single-line 40 character display can be achieved by increasing the number of extension drivers.

The extension driver can be interfaced with signals CL1, CL2, D1 and M. The following figure shows an example of HD66720 and an extension driver. The extension driver displays data from the 51st dot in 1-line display mode, and from the 43rd dot in 2-line display mode. The extension driver can be driven by the HD66720; however, the output voltage drop of the booster circuit increases as the load on the booster circuit increases.

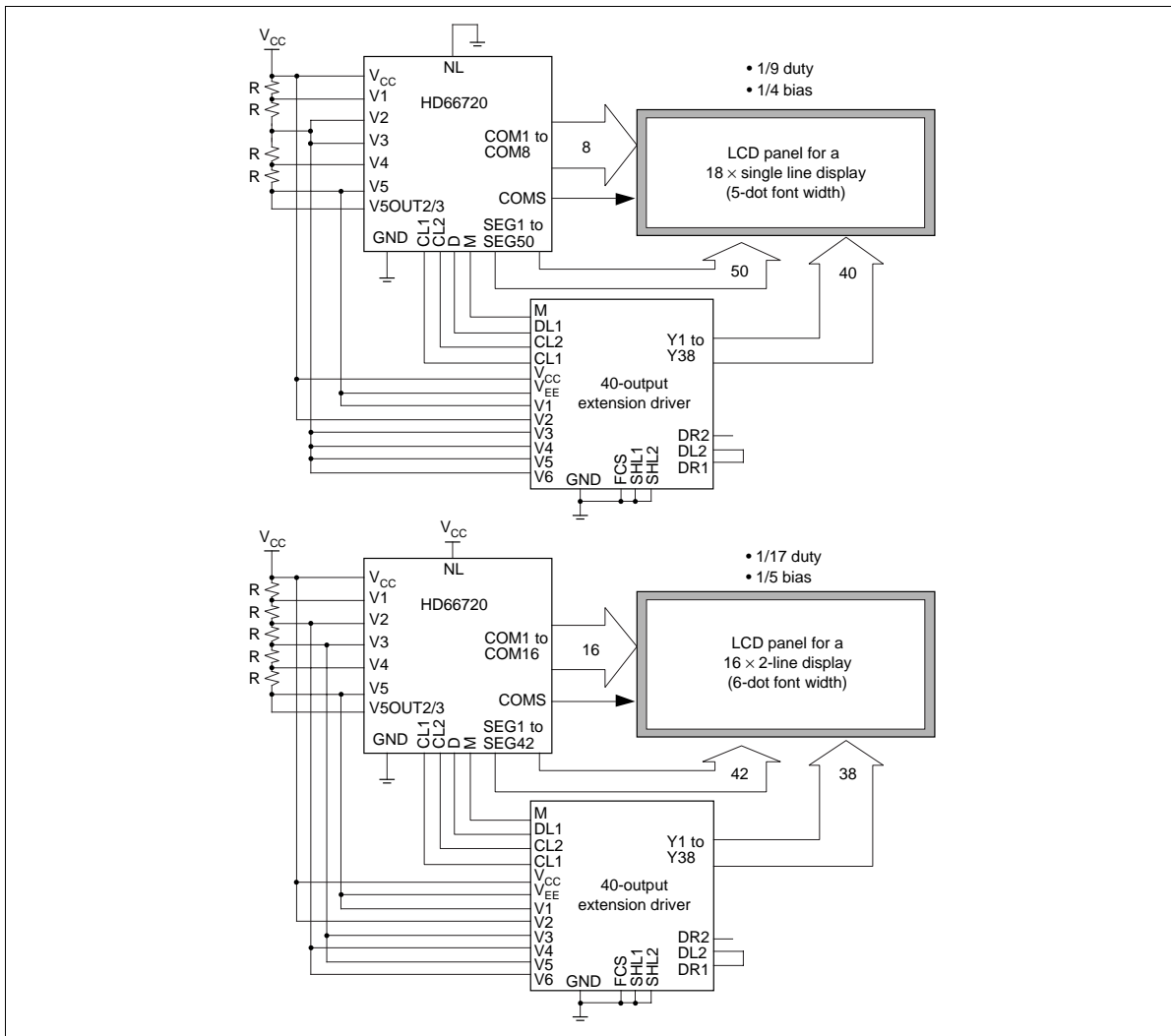


Figure 35 HD66720 and the Extension Driver Connection

Interface to the Liquid Crystal Display

Example of 5-Dot Font Width Connection

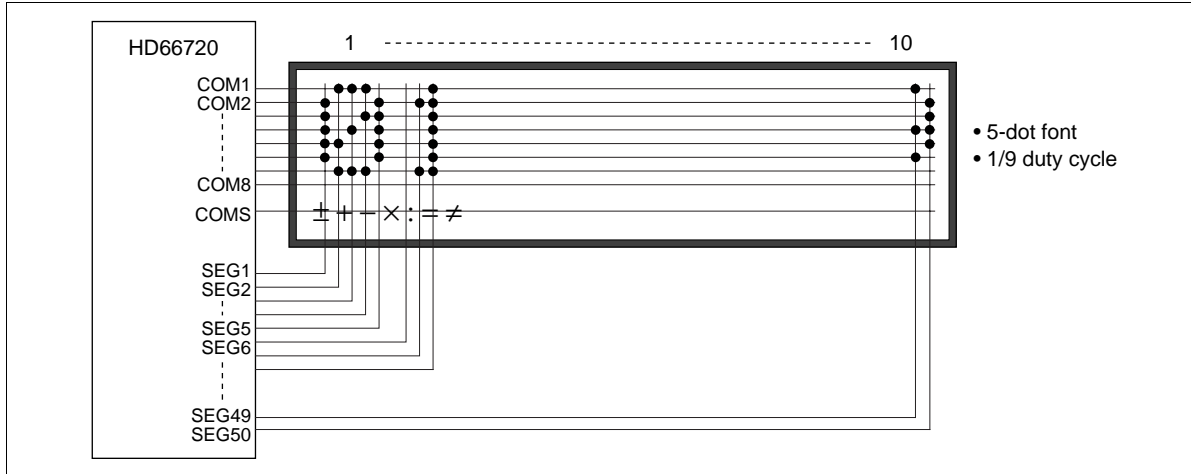


Figure 36 10 × 1-Line + 50-Segment Display

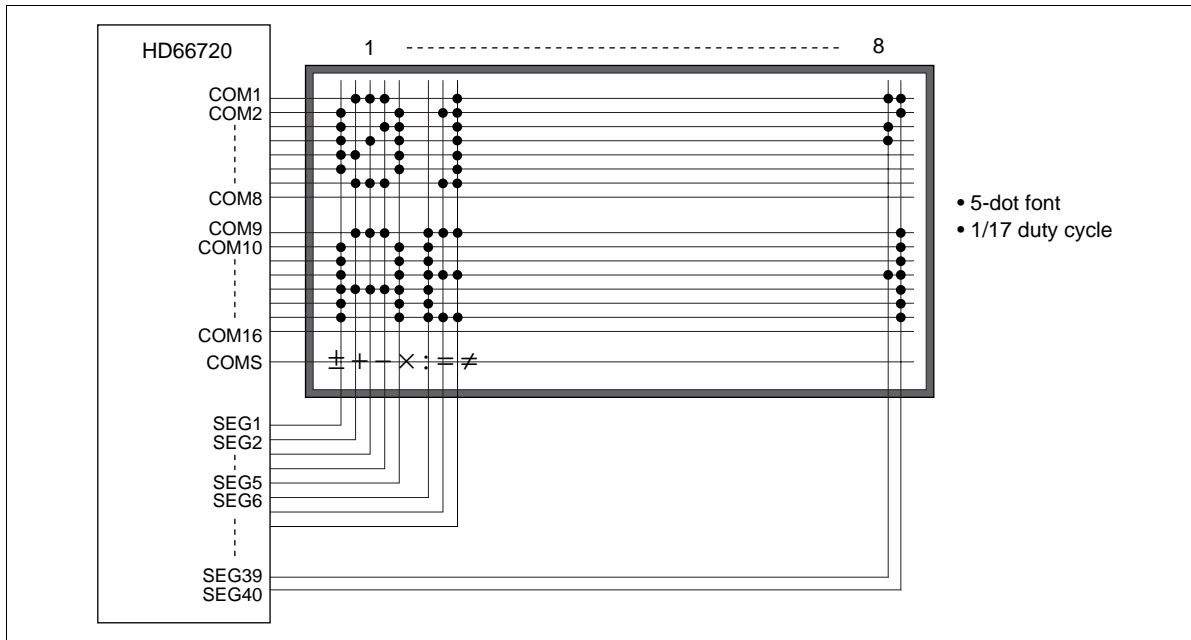
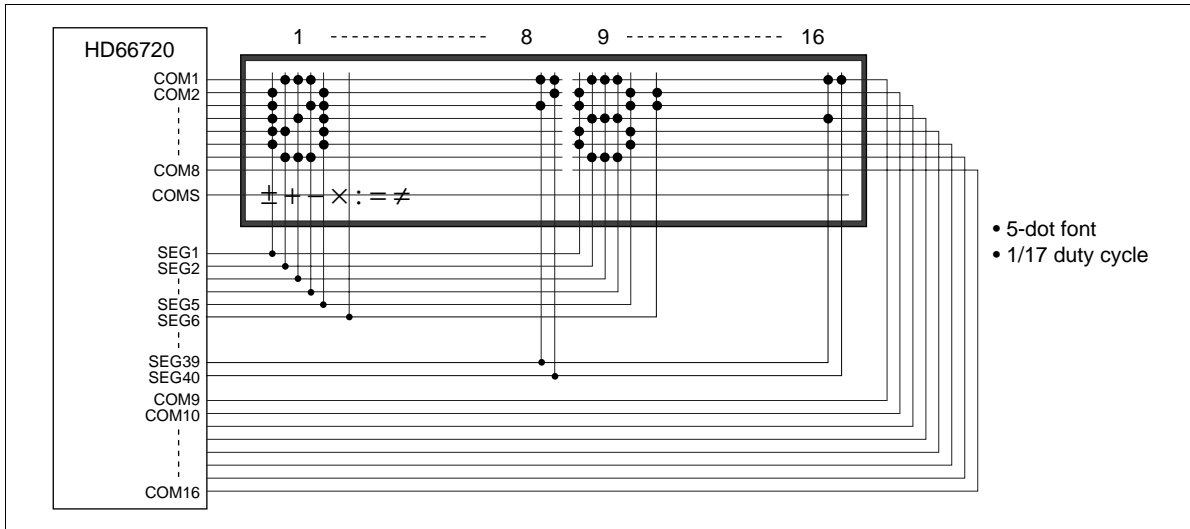
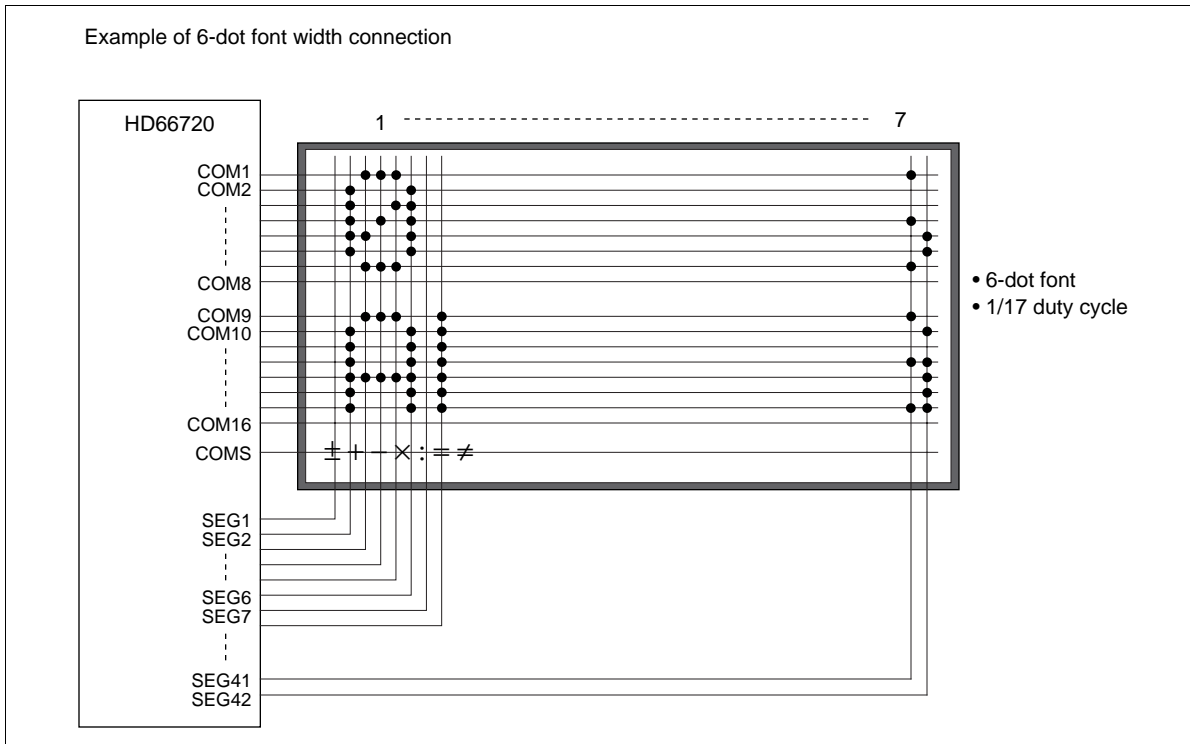


Figure 37 8 × 2-Line + 40-Segment Display

# HD66720



**Figure 38 16 × 1-Line + 40-Segment Display (Using the 8 × 2-line Operation Mode)**



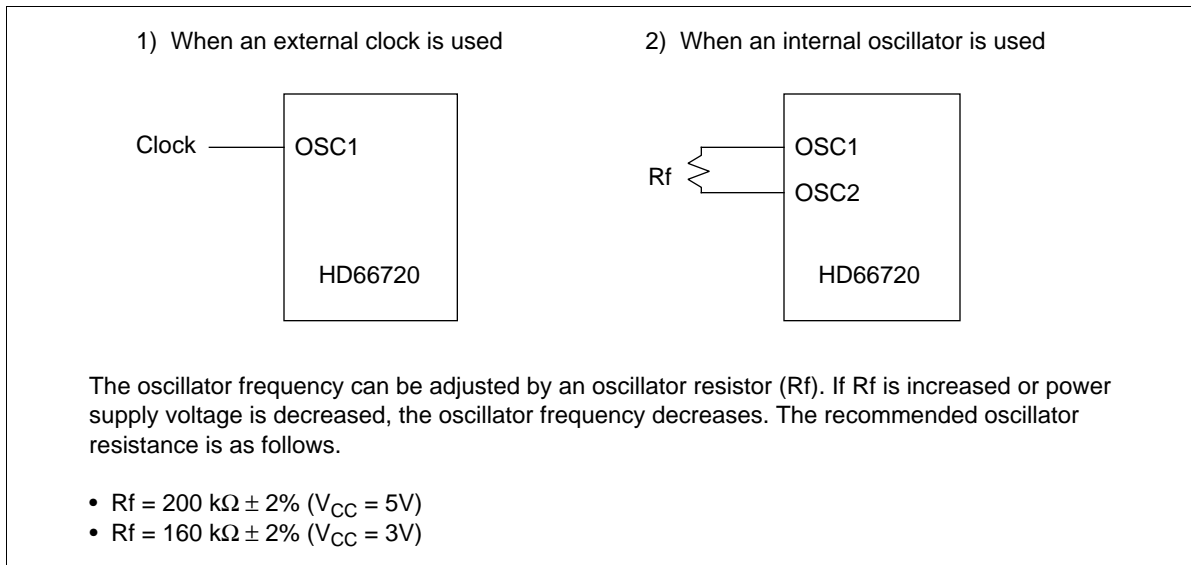
**Figure 39 7 × 2-Line + 42-Segment Display**

**Table 13 Relationship between Oscillation Circuit and Liquid Crystal Display Frame Frequency**

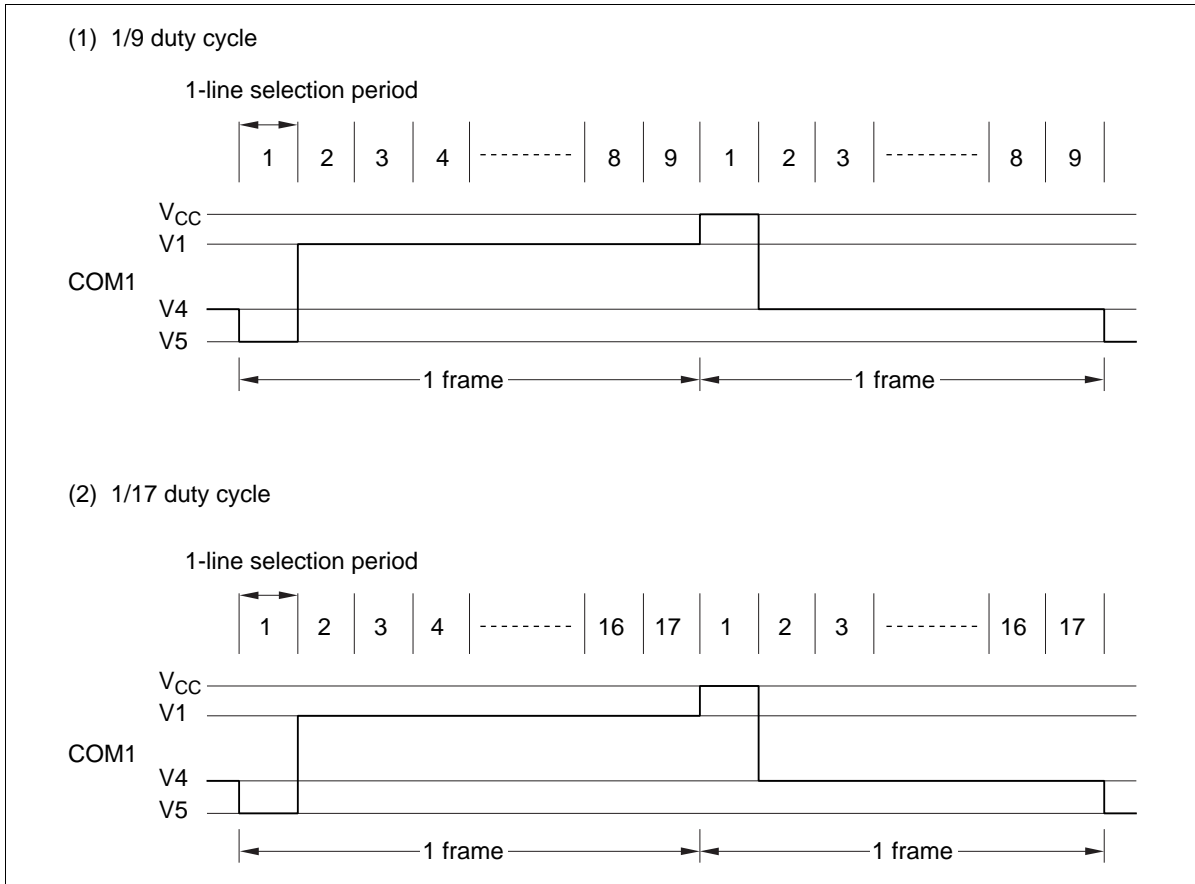
		1-Line Display		2-Line Display	
		5-Dot Font Width	6-Dot Font Width	5-Dot Font Width	6-Dot Font Width
1-Line Selection period	Normal mode	200 clock cycles	240 clock cycles	100 clock cycles	120 clock cycles
	LP mode	50 clock cycles	60 clock cycles	50 clock cycles	60 clock cycles
Frame frequency		88.9 Hz	74.1 Hz	94.1 Hz	78.4 Hz

Note: The above values are obtained when the oscillation frequency is 160 kHz (1 clock cycle is 6.25 μs).

**Oscillator**



**Figure 40 Oscillator**



**Figure 41 Frame Frequency**

### Power Supply for Liquid Crystal Display Drive

The HD66720 incorporates a booster for raising the LCD voltage 2-3 times that of the reference voltage input below  $V_{CC}$ . A 2-3 times boosted voltage can be obtained by externally attaching 2 or 3 capacitors.

If the LCD panel is large and needs a large amount of drive current, the value of bleeder resistor that generate the V1 to V5 potential are made smaller. However, the load current in the booster and the voltage drop increases in this case.

We recommend setting the resistance value of each bleeder larger than 4.7 k $\Omega$  and to hold down the DC load current to 0.4 mA if using a booster circuit. An external power supply should supply LCD voltage if the DC load current exceeds 0.7 mA. Refer to Electrical Characteristics showing the relationship between the load current and booster voltage output.

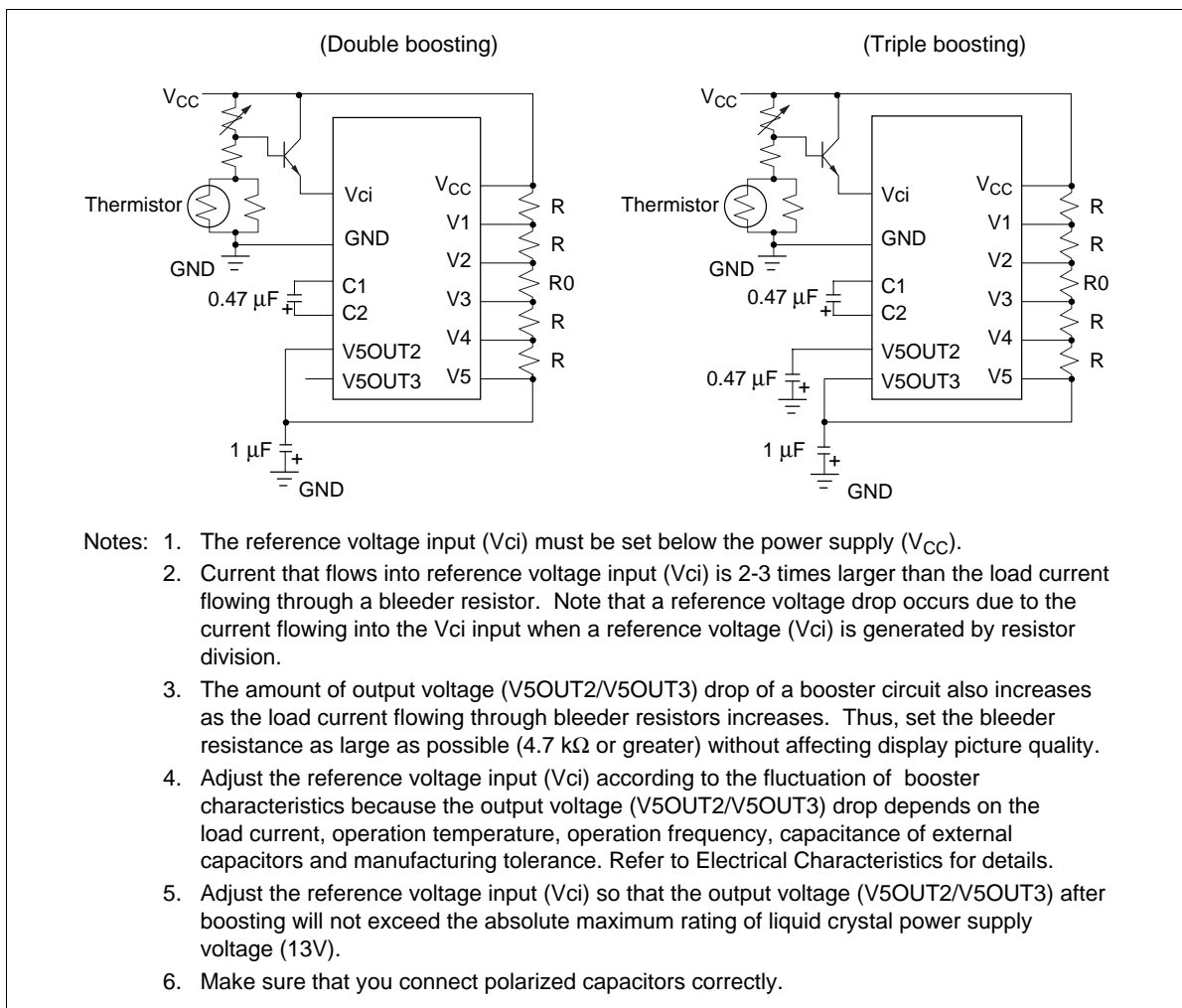


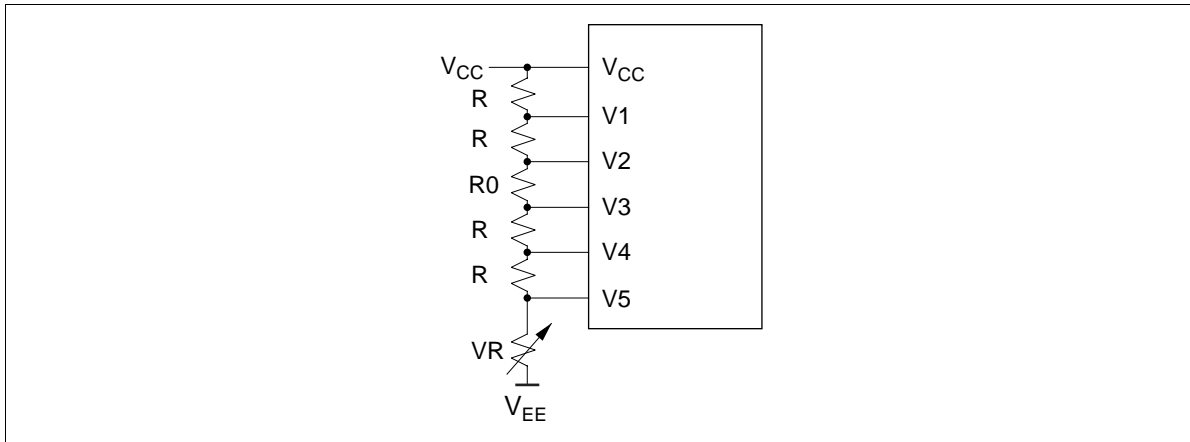
Figure 42 Example of Power Supply for Liquid Crystal Display Drive (with Internal Boost Circuit)

## HD66720

**Table 14 Duty Factor and Bleeder Resistor Value for Power Supply for Liquid Crystal Display Drive**

Item	Data		
Number of Lines	1	2	
Duty factor	1/9	1/17	
Bias	1/4	1/5	
Bleeder resistance value	R	R	R
	R0	To be short-circuited	R

Note: R changes depending on the size of a liquid crystal panel. Normally, R must be 5 kΩ to 20 kΩ.



**Figure 43 Example of Power Supply for Liquid Crystal Display Drive (with External Power Supply)**

### Font Display Control

The font width can be specified as 5 dots or 6 dots by setting the font width bit (FW) when the extension register is enabled (RE = 1). Although all fonts stored in CGROM have a 5-dot width, a smoother scroll can be displayed with a 6-dot wide font. Display data stored in CGROM/CGRAM/ SEGRAM can be displayed as a mirror image (reflection) in the horizontal direction by setting the font reverse bit (FR). Select according to the LSI mounting method. Set character codes in DDRAM by software since the display read-order of DDRAM does not change.

### Horizontal Dot Scroll

Dot unit scrolls are performed by setting the horizontal dot scroll bit (HDS) when the extension register is enabled (RE = 1). By combining this with scroll enable registers, smooth horizontal scrolling in the unit of display line can be performed. In this case, smoother scroll can be performed for a 6-dot font-width display.

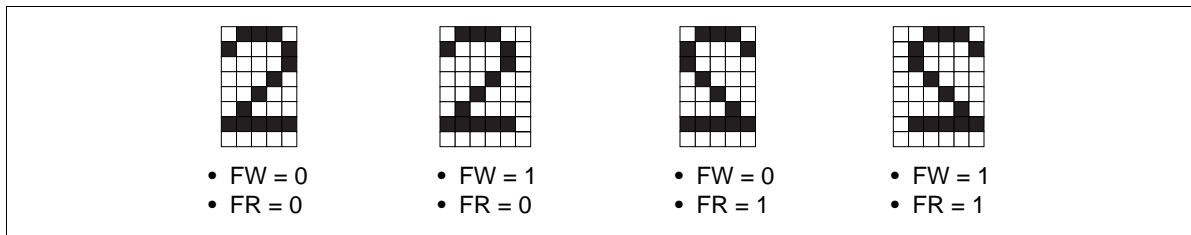


Figure 44 Example of Font Display Control

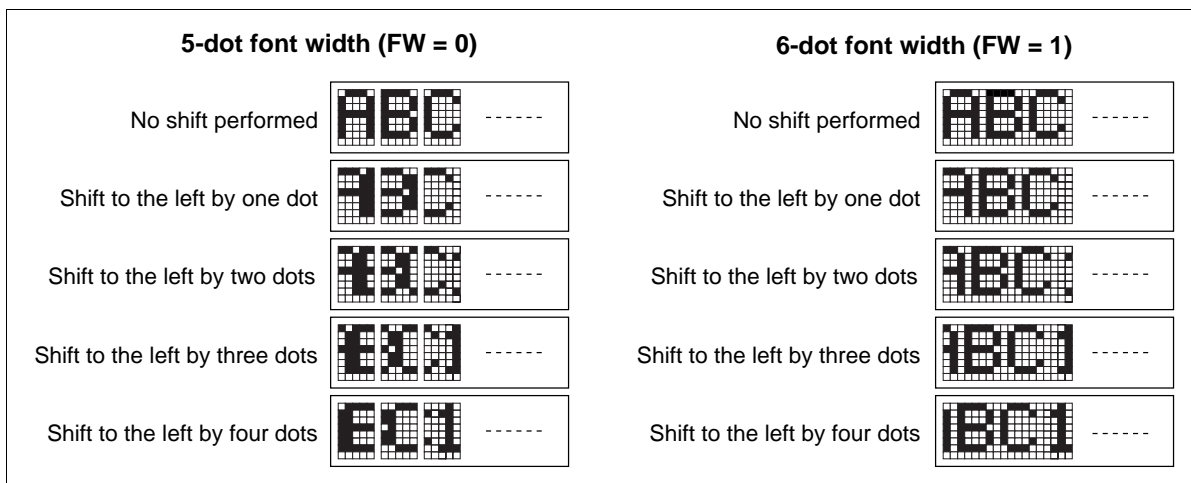
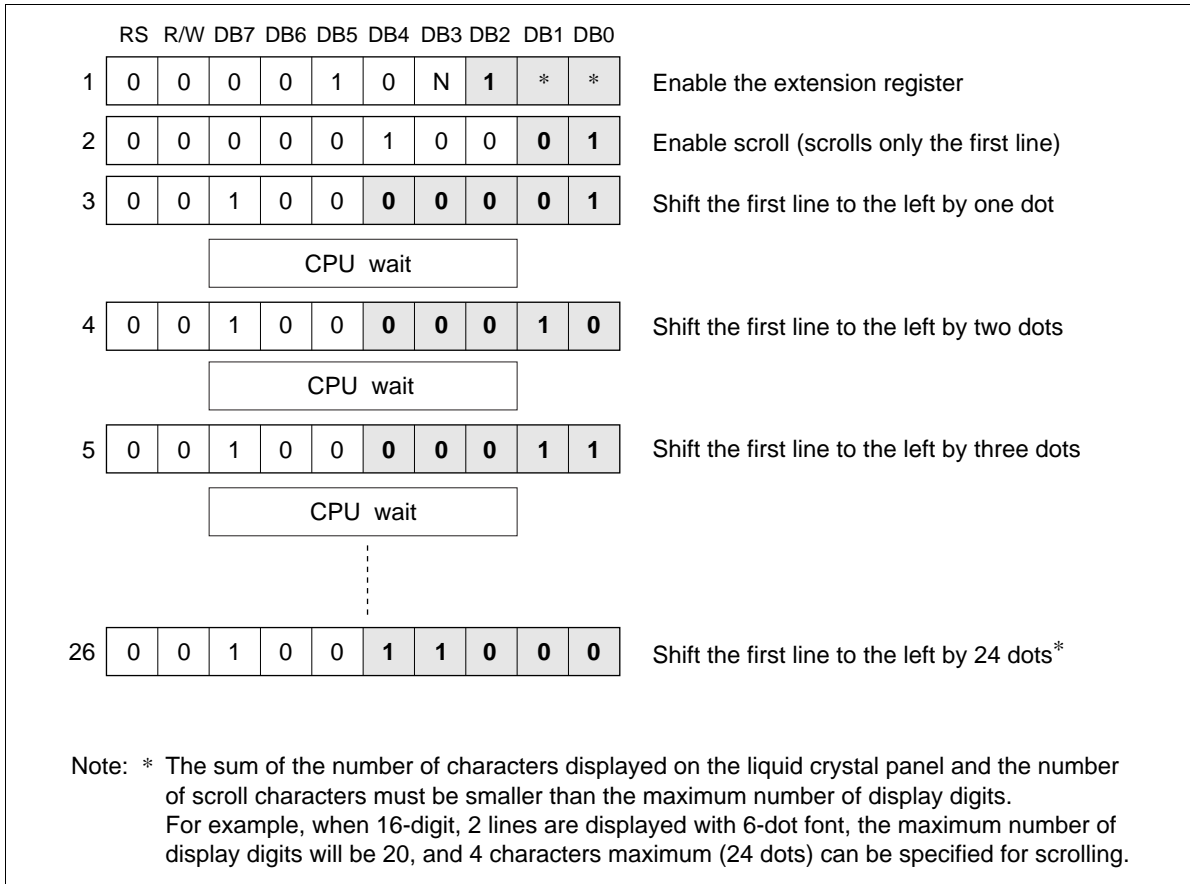


Figure 45 Example of Smooth Scroll Display

## Smooth Scroll to the Left

The following shows an example of smooth scroll to the left for no font reflection (FR = 0) and a 6-dot font width (FW = 1). Because the maximum setting for dot smooth scroll (HDS) is 24 dots, scrolling for more than this number can be achieved by shifting to the left by four characters with a display shift instruction or by moving the data in DDRAM by four characters, rewriting them, and then scrolling again. When shifting the display character position with a display shift instruction, the 1st and 2nd line are shifted at the same time and then displayed.



**Figure 46 Method of Smooth Scroll to the Left**

### Smooth Scroll to the Right

The following shows an example of smooth scroll to the right for no font reflection (FR = 0) and a 6-dot font width (FW = 1). Because the setting for dot smooth scroll (HDS) specifies a scroll to the left, scrolling to the right can be performed by first shifting the display character position to the right by four characters with a display shift instruction, or by moving the data in DDRAM for only lines to be scrolled by four characters, rewriting, and then scrolling from the 24th dot. When shifting the display character position with a display shift instruction, the 1st and 2nd line are shifted at the same time and then displayed.

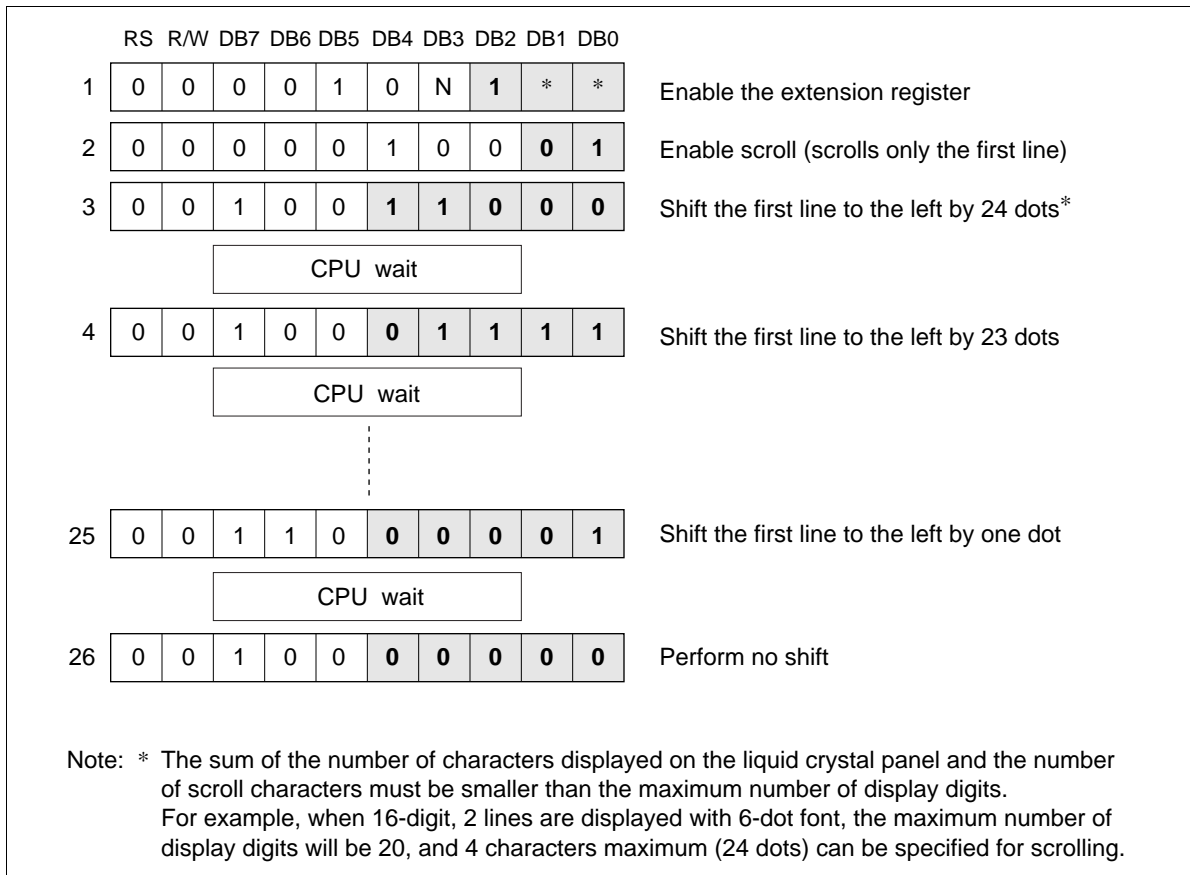
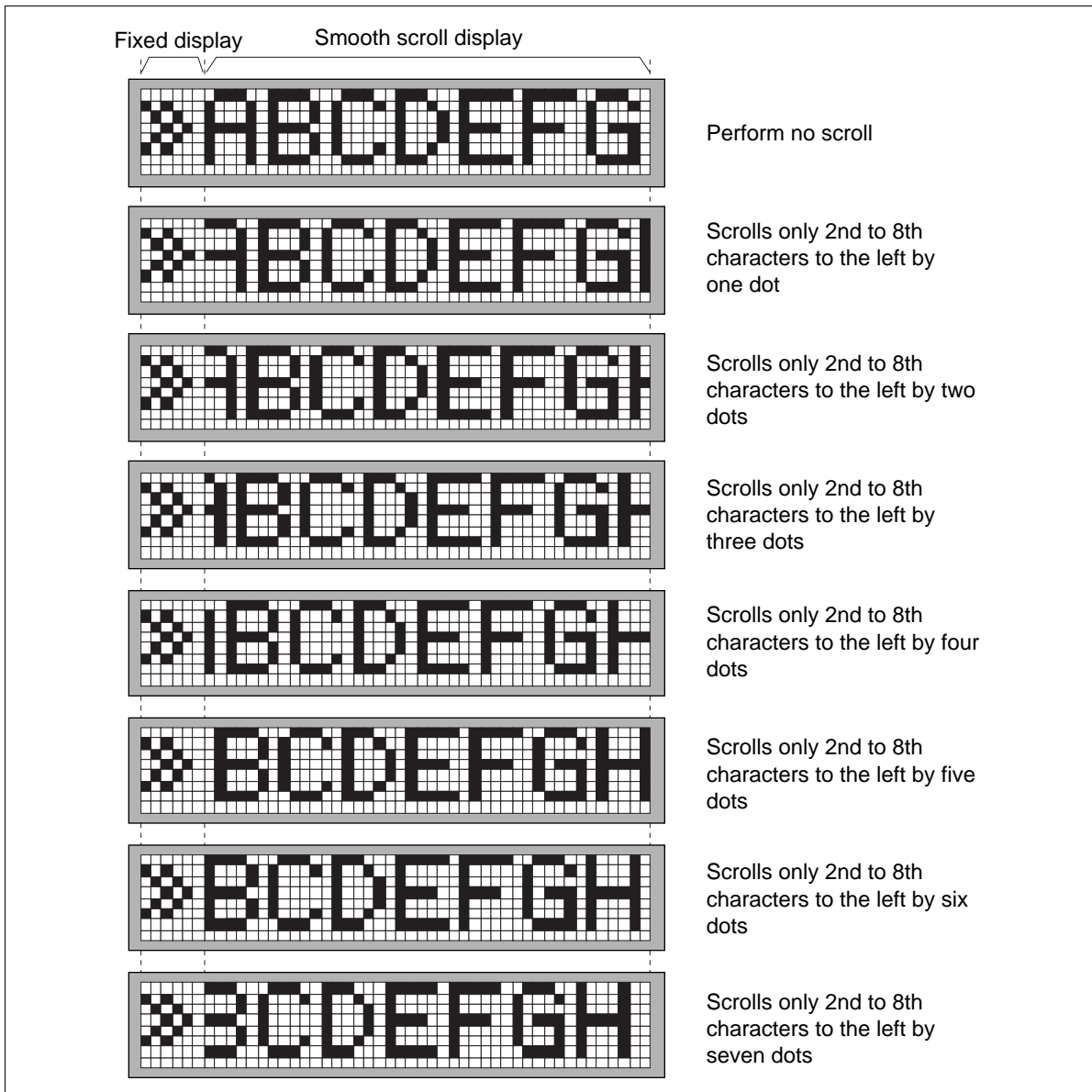


Figure 47 Method of Smooth Scroll to the Right

**Partial Smooth Scroll (Limiting the Number of Characters Scrolled)**

Partial smooth scroll displays some characters as fixed and the remaining ones in a horizontal smooth scroll. Here, only the number of left-most characters specified by the PS I/O bits can be fixed. The following shows an example of a smooth scroll performed in dot units from the second character to the eighth character with the PS1/O set to 01 so that the left-most character on the display panel is fixed. For a 2-line display, partial smooth scroll is performed for the display line specified by the scroll enable bits (SE2/1).

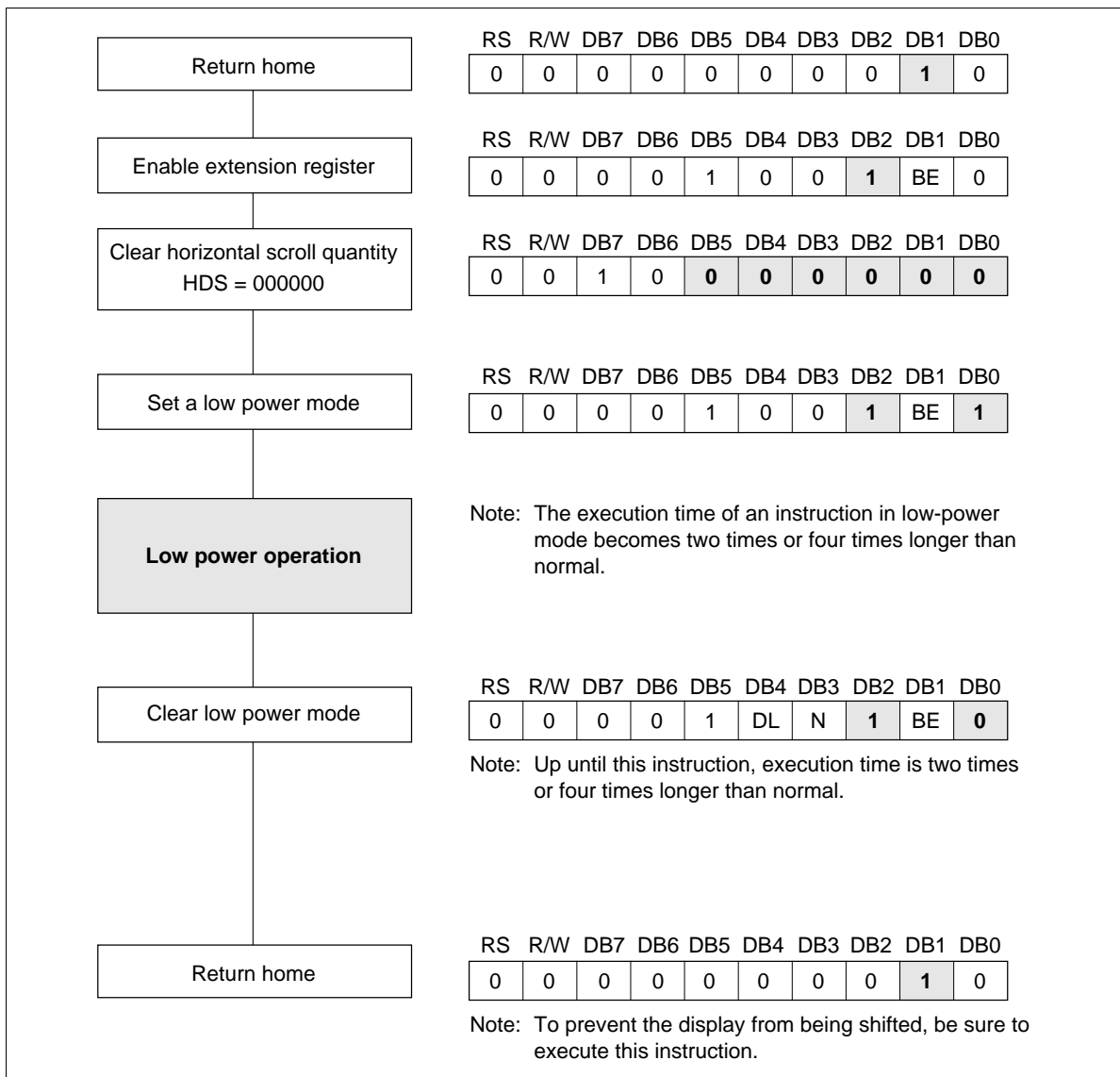


**Figure 48 Partial Smooth Scroll**

**Low Power Mode**

The HD66720 enters low power mode by setting the low-power mode bit (LP) to 1. During low-power mode, as the internal operation frequency is divided by 2 (1-line display mode) or by 4 (2-line display mode), the execution time of each instruction becomes two times or four times longer than normal. Be careful when writing instructions without performing busy flag checking.

During low power mode, a maximum of 10 characters are displayed per line. The DDRAM setting value become invalid from the 11th character. Note that the display differs from normal mode when display shifts or horizontal smooth scrolls are performed.



**Figure 49 Usage of Low Power Mode**

## Sleep Mode

The HD66720 enters sleep mode by setting the sleep mode bit (SLP) to 1. During sleep mode, the display controller and LCD internal operation frequency is divided by 16, significantly reducing consumption current. However, the LCD will not perform normally at this time because the LCD frame frequency is also divided by 16, and the display should be turned off (D = 0). In addition, execution time of each instruction becomes 16 times longer, and caution is needed when writing instructions without performing busy flag checking. The key scan circuit during sleep mode operates at the usual operation frequency. Key scan such as power-on keys can be performed by suppressing consumption current during system standby.

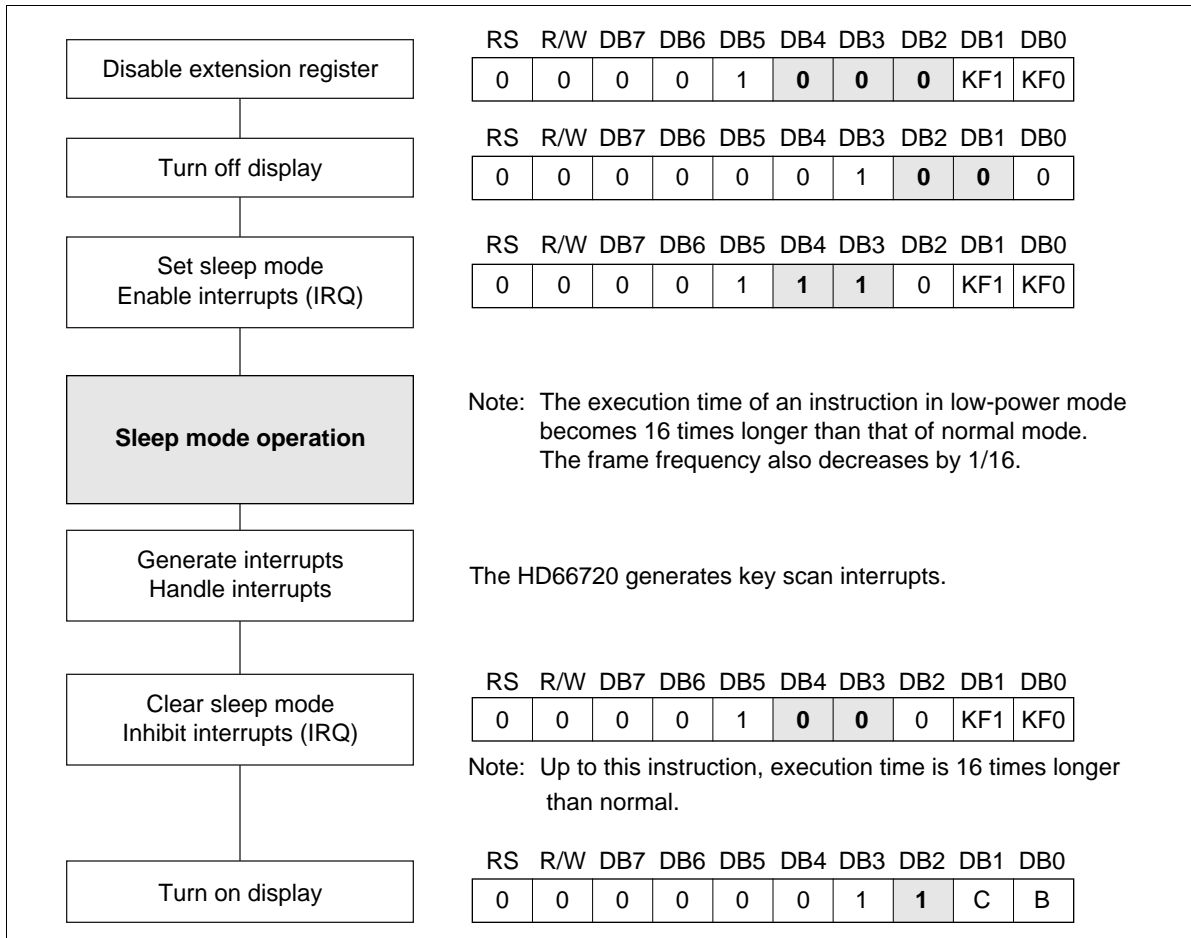
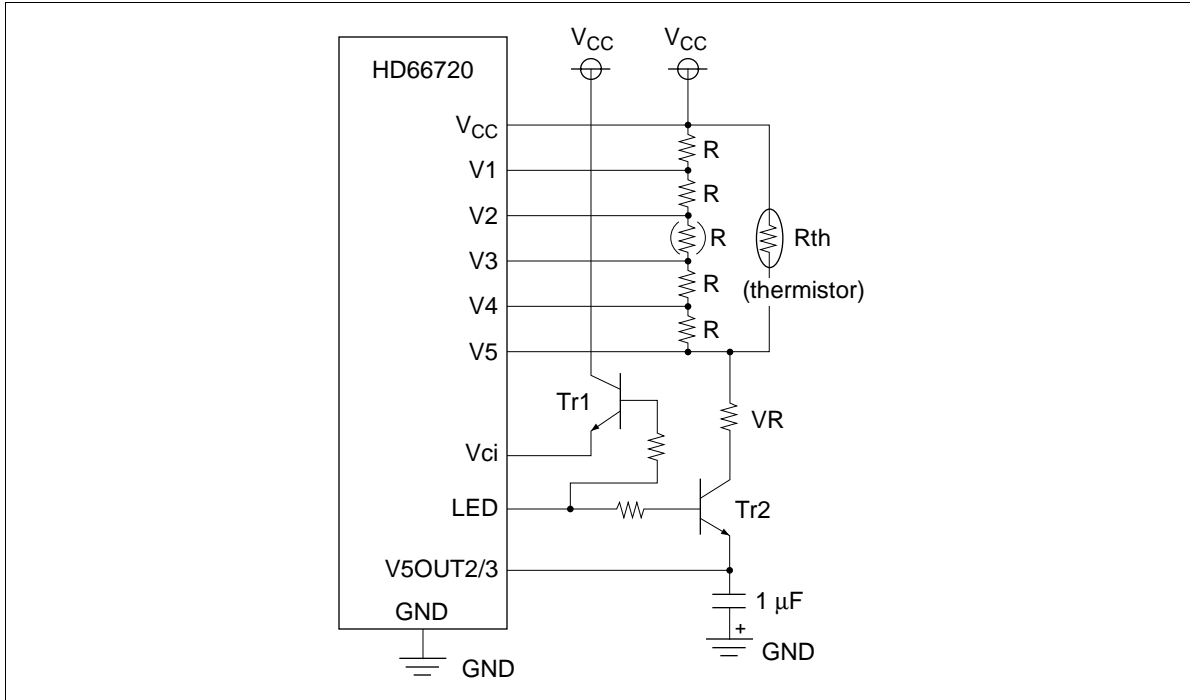


Figure 50 Usage of Sleep Mode

The shut-down circuit of LCD driving circuit (VLCD) is shown below. The Vci input for an internal booster should be shut down to GND level (= 0V) with Tr1, the bleeder resistors should be cut off with Tr2 during the sleep mode. These transistor can be controlled with the LED output port of HD66720. This circuit can be also save unnecessary current through the bleeder resistors during the sleep mode.



**Figure 51 Example of LCD Driving Circuit with Thermistor for Sleep Mode**

# HD66720

## Relationship between Instruction and Display

**Table 15 10-Digit × 1-Line Display Example with Internal Reset**

Step No.	Instruction										Display	Operation
	RS	R/W	DB7	DB6	DB5	DB4	DB3	DB2	DB1	DB0		
1	Power supply on (the HD66720 is initialized by the internal reset circuit)										<input type="text"/>	Initialized. No display.
2	0	0	0	0	0	0	1	1	1	0	<input type="text" value="-"/>	Turns on display and cursor. Entire display is in space mode because of initialization.
3	0	0	0	0	0	0	1	1	0		<input type="text" value="-"/>	Sets mode to increment the address by one and to shift the cursor to the right when writing to the RAM. Display is not shifted.
4	1	0	0	1	0	0	1	0	0	0	<input type="text" value="H_"/>	Writes H. DDRAM has already been selected by initialization.
5	1	0	0	1	0	0	1	0	0	1	<input type="text" value="HI_"/>	Writes I.
											<input type="text" value="."/>	
											<input type="text" value="."/>	
											<input type="text" value="."/>	
											<input type="text" value="."/>	
6	1	0	0	1	0	0	1	0	0	1	<input type="text" value="HITACHI_"/>	Writes I.
7	0	0	0	0	0	0	0	1	1	1	<input type="text" value="HITACHI_"/>	Sets mode to shift display at the time of write.
8	1	0	0	0	1	0	0	0	0	0	<input type="text" value="ITACHI _"/>	Writes a space.

Table 15 10-Digit × 1-Line Display Example with Internal Reset (cont)

Step		Instruction									Display	Operation		
No.	RS	R/W	DB7	DB6	DB5	DB4	DB3	DB2	DB1	DB0				
9		Write data to CGRAM/DDRAM	1	0	0	1	0	0	1	1	0	1	I T A C H I M _	Writes M.
		.											.	
		.											.	
		.											.	
		.											.	
10		Write data to CGRAM/DDRAM	1	0	0	1	0	0	1	1	1	1	M I C R O C O _	Writes O.
11		Cursor or display shift	0	0	0	0	0	1	0	0	0	0	M I C R O C O _	Shifts only the cursor position to the left.
12		Cursor or display shift	0	0	0	0	0	1	0	0	0	0	M I C R O C O _	Shifts only the cursor position to the left.
13		Write data to CGRAM/DDRAM	1	0	0	1	0	0	0	0	1	1	I C R O C O _	Writes C. The display moves to the left.
14		Cursor or display shift	0	0	0	0	0	1	1	1	0	0	M I C R O C O _	Shifts the display and cursor position to the right.
15		Cursor or display shift	0	0	0	0	0	1	0	1	0	0	M I C R O C O _	Shifts the display and cursor position to the right.
16		Write data to CGRAM/DDRAM	1	0	0	1	0	0	1	1	0	1	I C R O C O M _	Writes M.
		.											.	
		.											.	
		.											.	
		.											.	
		.											.	
17		Return home	0	0	0	0	0	0	0	0	1	0	H I T A C H I	Returns both display and cursor to the original position (address 0).

# HD66720

**Table 16 8-Digit × 2-Line Display Example with Internal Reset**

Step No.	RS	R/W	DB7	DB6	DB5	DB4	DB3	DB2	DB1	DB0	Display	Operation
1												Initialized. No display.
2	0	0	0	0	0	0	1	1	1	0		Turns on display and cursor. Entire display is in space mode because of initialization.
3	0	0	0	0	0	0	0	1	1	0		Sets mode to increment the address by one and to shift the cursor to the right at the time of write to the RAM. Display is not shifted.
4	1	0	0	1	0	0	1	0	0	0		Writes H. DDRAM has already been selected by initialization.
5	1	0	0	1	0	0	1	0	0	1		Writes I.
6	0	0	1	1	0	0	0	0	0	0		Sets the DDRAM address so that the cursor positioned on the head of the second line.
7	1	0	0	1	0	0	1	1	0	1		Writes a space.
8	1	0	0	1	0	0	1	1	1	1		Writes O.
9	0	0	0	0	0	0	0	1	1	1		Sets mode to shift display at the time of write.
10	1	0	0	1	0	0	1	1	0	1		Writes M.
11	0	0	0	0	0	0	0	0	1	0		Returns both display and cursor to the original position (address0).

### Initializing by Instruction

If the power supply conditions for correctly operating the internal reset circuit are not met, initialization by instructions becomes necessary. Note that instructions are not accepted for 80 ms in 3-V operation or for 40 ms in 5-V operation after power is on since the HD66720 is in an internal reset state. Send an instruction after waiting for an appropriate amount of time after power-on.

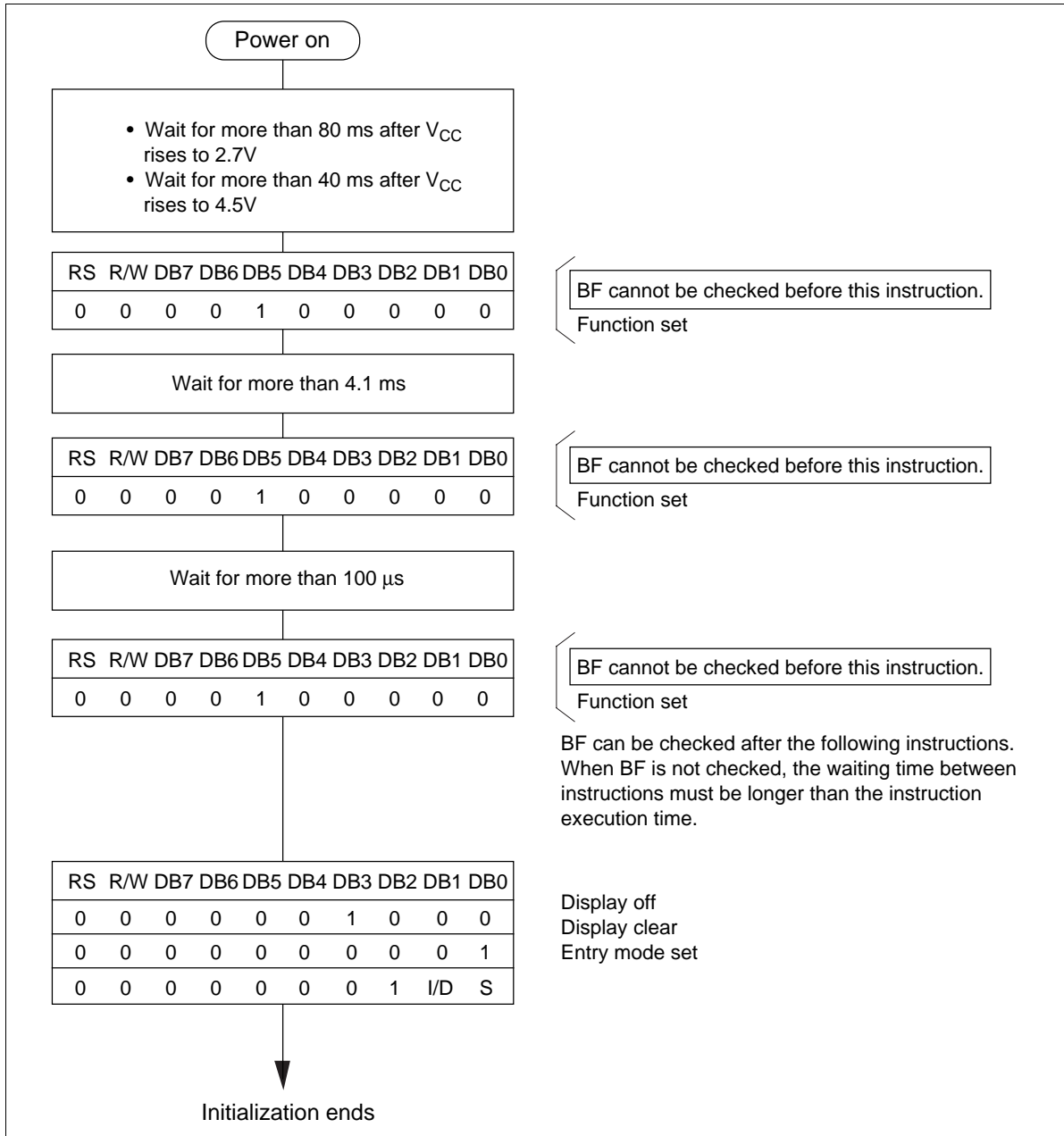


Figure 52 Initializing Flow

---

## HD66720

---

### Absolute Maximum Ratings\*

Item	Symbol	Value	Unit	Notes
Power supply voltage (1)	$V_{CC}$	-0.3 to +7.0	V	1
Power supply voltage (2)	$V_{CC}-V_5$	-0.3 to +13.0	V	1, 2
Input voltage	$V_t$	-0.3 to $V_{CC} + 0.3$	V	1
Operating temperature	$T_{opr}$	-30 to +75	°C	
Storage temperature	$T_{stg}$	-55 to +125	°C	4

Note: \* If the LSI is used above these absolute maximum ratings, it may become permanently damaged. Using the LSI within the following electrical characteristic limits is strongly recommended for normal operation. If these electrical characteristic conditions are exceeded, the LSI will malfunction and cause poor reliability.

**DC Characteristics ( $V_{CC} = 2.7V$  to  $5.5V$ ,  $T_a = -30$  to  $+75^\circ C^{*3}$ )**

Item	Symbol	Min	Typ	Max	Unit	Test Condition	Notes	
Input high voltage (1) (except OSC1)	VIH1	$0.7V_{CC}$	—	$V_{CC}$	V		5, 6	
Input low voltage (1) (except OSC1)	VIL1	-0.3	—	$0.2V_{CC}$	V	$V_{CC} = 2.7$ to $3.0V$	5, 6	
		-0.3	—	0.6	V	$V_{CC} = 3.0$ to $4.5V$		
Input high voltage (2) (OSC1)	VIH2	$0.7V_{CC}$	—	$V_{CC}$	V		7	
Input low voltage (2) (OSC1)	VIL2	—	—	$0.2V_{CC}$	V		7	
Output high voltage (1) (except KST, IRQ*)	VOH1	$0.75V_{CC}$	—	—	V	$-I_{OH} = 0.1$ mA	5, 8	
Output high voltage (2) (KST, IRQ*)	VOH2	$0.7V_{CC}$	—	—	V	$-I_{OH} = 0.5$ $\mu A$	5, 10	
Output low voltage (1) (except KST, LED, IRQ*)	VOL1	—	—	$0.2V_{CC}$	V	$I_{OL} = 0.1$ mA	5, 9	
Output low voltage (2) (KST, IRQ*)	VOL2	—	—	$0.2V_{CC}$	V	$I_{OL} = 0.5$ mA	5, 10	
Output low voltage (3) (LED 0/1)	VOL3	—	—	1.2	V	$I_{OL} = 10$ mA, $V_{CC} = 3V$	5, 11	
Driver ON resistance (COM)	$R_{COM}$	—	2	20	k $\Omega$	$\pm I_d = 0.05$ mA (COM) VLCD = 4V	12	
Driver ON resistance (SEG)	$R_{SEG}$	—	2	30	k $\Omega$	$\pm I_d = 0.05$ mA (SEG) VLCD = 4V	12	
I/O leakage current	$I_{LI}$	-1	—	1	$\mu A$	$V_{IN} = 0$ to $V_{CC}$	13	
Pull-up MOS current (KIN0-KIN4)	$-I_p$	1	10	40	$\mu A$	$V_{CC} = 3V$ , $V_{in} = 0V$	5, 14	
Current consumption	Normal display	$I_{CC1}$	—	85	170	$\mu A$	Rf oscillation, external clock $V_{CC} = 3V$ , $f_{OSC} = 160$ kHz	15, 16
	Sleep mode	$I_{CC2}$	—	40	100	$\mu A$		
LCD voltage	VLCD1	3.0	—	11.0	V	$V_{CC} - V_5$ , 1/4, 1/5 bias	17	

**Booster Characteristics**

Item	Symbol	Min	Typ	Max	Unit	Test Condition	Notes
Output voltage (V5OUT2 pin)	VUP2	7.5	8.7	—	V	$V_{ci} = 4.5V$ , $I_o = 0.25$ mA, $T_a = 25^\circ C$	20, 21
Output voltage (V5OUT3 pin)	VUP3	7.0	7.8	—	V	$V_{ci} = 3V$ , $I_o = 0.25$ mA, $T_a = 25^\circ C$	20, 21
Input voltage	$V_{ci}$	1.0	—	5.0	V	$V_{ci} \leq V_{CC}$	20, 21, 22

## HD66720

### AC Characteristics ( $V_{CC} = 2.7V$ to $5.5V$ , $T_a = -30$ to $+75^{\circ}C^{*3}$ )

#### Clock Characteristics ( $V_{CC} = 2.7V$ to $5.5V$ , $T_a = -30$ to $+75^{\circ}C^{*3}$ )

Item		Symbol	Min	Typ	Max	Unit	Test Condition	Notes*
External clock operation	External clock frequency	$f_{cp}$	100	150	400	kHz		18
	External clock duty cycle	Duty	45	50	55	%		
	External clock rise time	$t_{rcp}$	—	—	0.2	$\mu s$		
	External clock fall time	$t_{rcp}$	—	—	0.2	$\mu s$		
Rf oscillation	Clock oscillation frequency	$f_{osc}$	120	160	210	kHz	$R_f = 160\text{ k}\Omega$ , $V_{CC} = 3V$	19

#### Serial Interface Timing (1) ( $V_{CC} = 2.7V$ to $4.5V$ , $T_a = -30$ to $+75^{\circ}C^{*3}$ )

Item	Symbol	Min	Typ	Max	Unit	Test Condition
Serial clock cycle time	$t_{SCYC}$	1	—	20	$\mu s$	Figure 54
Serial clock high level width	$t_{SCH}$	400	—	—	ns	
Serial clock low level width	$t_{SCL}$	400	—	—		
Serial clock rise/fall time	$t_{SCr}$ , $t_{SCf}$	—	—	50		
Chip select set-up time	$t_{CSU}$	60	—	—		
Chip select hold time	$t_{CH}$	200	—	—		
Serial input data set-up time	$t_{SISU}$	200	—	—		
Serial input data hold time	$t_{SIH}$	200	—	—		
Serial output data delay time	$t_{SOD}$	—	—	360		
Serial output data hold time	$t_{SOH}$	0	—	—		

**Serial Interface Timing (2) ( $V_{CC} = 4.5V$  to  $5.5V$ ,  $T_a = -30$  to  $+75^\circ C^{*3}$ )**

Item	Symbol	Min	Typ	Max	Unit	Test Condition
Serial clock cycle time	$t_{SCYC}$	0.5	—	20	$\mu s$	Figure 54
Serial clock high level width	$t_{SCH}$	200	—	—	ns	
Serial clock low level width	$t_{SCL}$	200	—	—		
Serial clock rise/fall time	$t_{SCr}$ , $t_{SCf}$	—	—	50		
Chip select set-up time	$t_{CSU}$	60	—	—		
Chip select hold time	$t_{CH}$	100	—	—		
Serial input data set-up time	$t_{SISU}$	100	—	—		
Serial input data hold time	$t_{SIH}$	100	—	—		
Serial output data delay time	$t_{SOD}$	—	—	160		
Serial output data hold time	$t_{SOH}$	0	—	—		

**Segment Extension Signal Timing ( $V_{CC} = 2.7V$  to  $5.5V$ ,  $T_a = -30$  to  $+75^\circ C^{*3}$ )**

Item		Symbol	Min	Typ	Max	Unit	Test Condition
Clock pulse width	High level	$t_{CWH}$	500	—	—	ns	Figure 53
	Low level	$t_{CWL}$	500	—	—		
Clock set-up time		$t_{CSU}$	500	—	—		
Data set-up time		$t_{SU}$	300	—	—		
Data hold time		$t_{DH}$	300	—	—		
M delay time		$t_{DM}$	-1000	—	1000		
Clock rise/fall time		$t_{ct}$	—	—	200		

**Key Scan Characteristics ( $V_{CC} = 2.7V$  to  $5.5V$ ,  $T_a = -30$  to  $+75^\circ C^{*3}$ )**

Item	KF1	KF0	Symbol	Min	Typ	Max	Unit	Test Condition
Key strobe frequency	0	0	$t_{KC}$	—	1536Tc	—	ms	Figure 56
	0	1	$t_{KC}$	—	768Tc	—		
	1	0	$t_{KC}$	—	3072Tc	—		
	1	1	$t_{KC}$	—	6144Tc	—		

Note:  $Tc = 1/f_{osc}$

---

## HD66720

---

### Reset Timing ( $V_{CC} = 2.7V$ to $5.5V$ , $T_a = -30$ to $+75^{\circ}C^{*3}$ )

Item	Symbol	Min	Typ	Max	Unit	Test Condition
Reset low-level width	$t_{RES}$	10	—	—	ms	Figure 57

### Power Supply Conditions Using Internal Reset Circuit

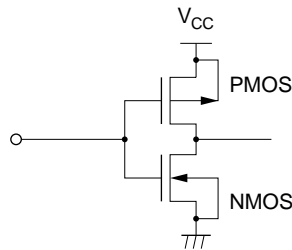
Item	Symbol	Min	Typ	Max	Unit	Test Condition
Power supply rise time	$t_{rCC}$	0.1	—	10	ms	Figure 58
Power supply off time	$t_{OFF}$	1	—	—		

**Electrical Characteristics Notes**

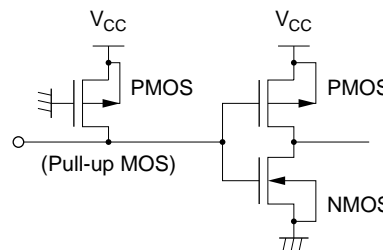
1. All voltage values are referred to GND = 0V. If the LSI is used above the absolute maximum ratings, it may become permanently damaged. Using the LSI within the electrical characteristic is strongly recommended to ensure normal operation. If these electrical characteristic conditions are exceeded, the LSI may malfunction or cause poor reliability.
2.  $V_{CC} \geq V_5$  must be maintained.
3. For die products, specified at 75°C.
4. For die products, specified by the die shipment specification.
5. The following four circuits are I/O pin configurations except for liquid crystal display output.

Input pin

Applies to pins SCLK, CS\*, SID, and TEST1/2

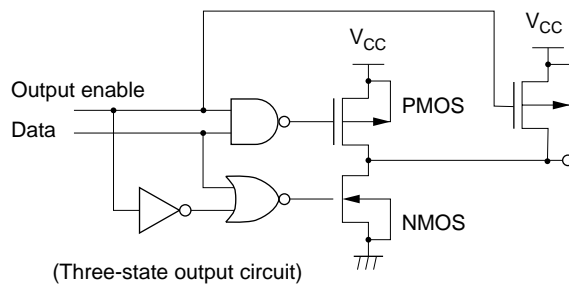


Applies to pins KIN0 to KIN4 and RESET\*

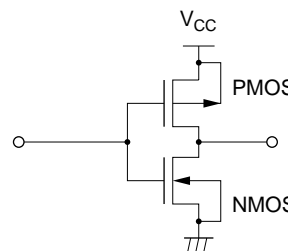


Output pin

Applies to pin SOD



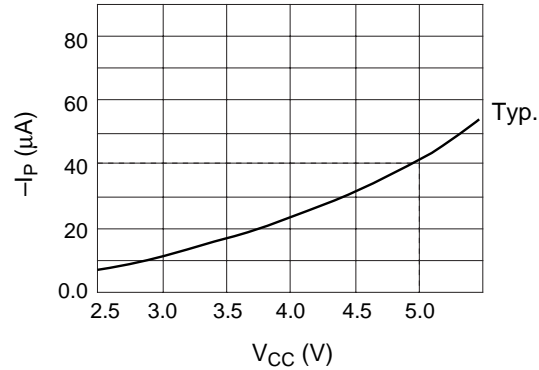
Applies to pins CL1, CL2, M, D, KST0 to KST5, IRQ\*, and LED0/1



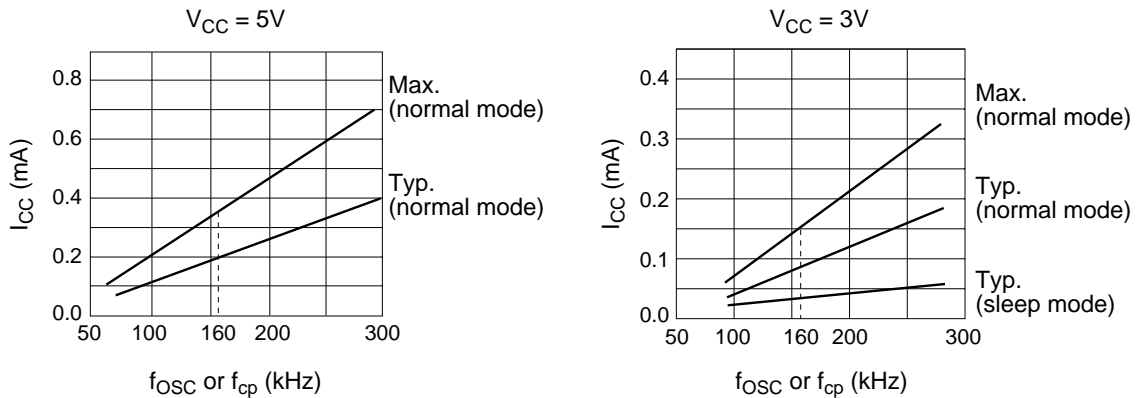
6. Applies to input pins, excluding the OSC1 pin. However, the TEST1/2 pins must be grounded (GND).
7. Applies to the OSC1 pin.
8. Applies to output pins, excluding pins KST0 to KST5, IRQ\*, and LCD output pins.
9. Applies to output pins, excluding pins KST0 to KST5, IRQ\*, pins LED0/1, and LCD output pins.
10. Applies to pins KST0 to KST5, and IRQ\*.

## HD66720

11. Applies to LED0/1 output pins.
12. Applies to resistor values (R<sub>COM</sub>) between power supply pins V<sub>CC</sub>, V1, V4, V5 and common signal pins (COM1 to COM16 and COMS), and resistor values (R<sub>SEG</sub>) between power supply pins V<sub>CC</sub>, V2, V3, V5, and segment signal pins (SEG1 to SEG42).
13. Current that flows through pull-up MOS and output drive MOS is excluded.
14. Applies to the pull-up MOS of pins KIN0 to KIN4. The following shows the relationship between the power supply voltage (V<sub>CC</sub>) and pull-up MOS current (-I<sub>p</sub>) (referential data).

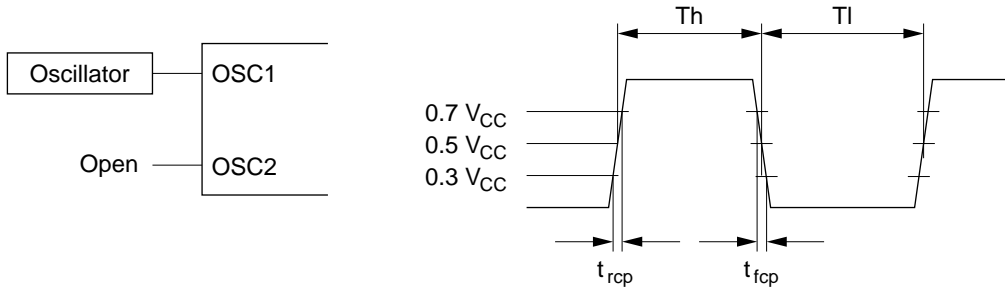


15. This excludes the current flowing through the I/O section. The input level must always be at a specified high or low level because through current increases if the CMOS input is left floating.
16. The following shows the relationship between the operation frequency (f<sub>OSC</sub> or f<sub>CP</sub>) and current consumption (I<sub>CC</sub>).



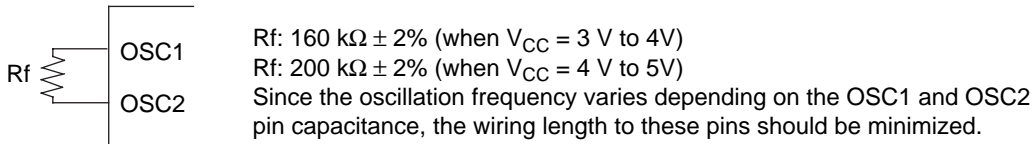
17. Each COM and SEG output voltage is within  $\pm 0.15V$  of the LCD voltage ( $V_{CC}$ , V1, V2, V3, V4, V5) when there is no load.

18. Applies to the external clock input.

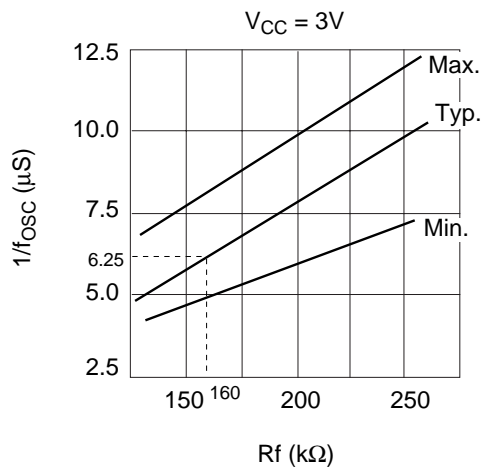
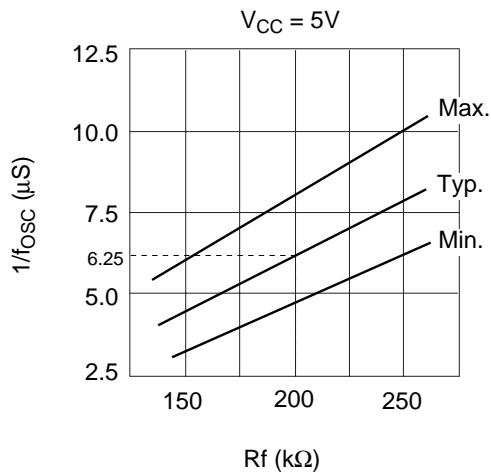


$$\text{Duty cycle} = \frac{T_h}{T_h + T_l} \times 100\%$$

19. Applies to internal oscillator operations when oscillator Rf is used.



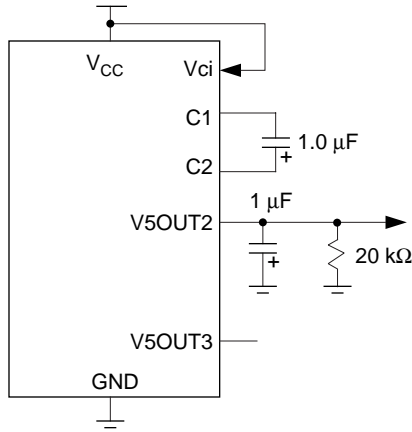
The following shows the relationship between the Rf oscillator resistor value and oscillator frequency (referential data).



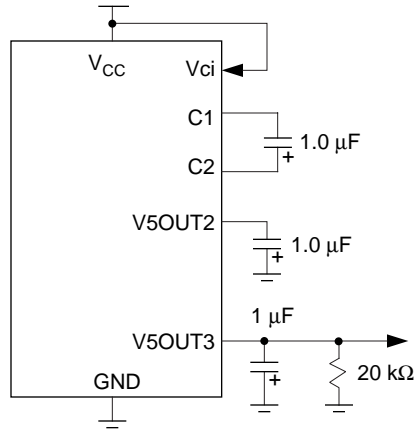
# HD66720

20. Booster characteristics test circuits are shown below.

(Double boosting)



(Triple boosting)



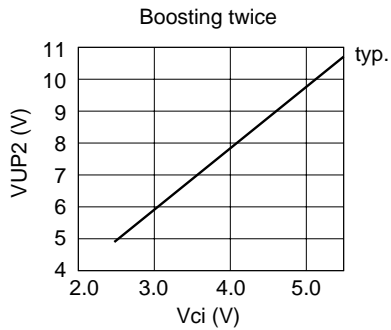
## 21. Reference data

The following graphs show the liquid crystal voltage booster characteristics.

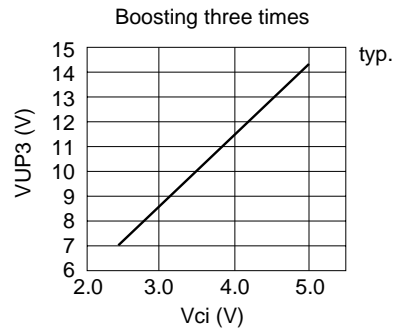
$$VUP2 = V_{CC} - V5OUT2$$

$$VUP3 = V_{CC} - V5OUT3$$

(1) VUP2, VUP3 vs Vci

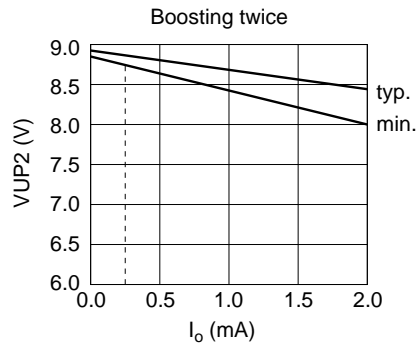


Test condition:  $V_{ci} = V_{CC}$ ,  $f_{cp} = 160$  kHz,  
 $T_a = 25^\circ\text{C}$ ,  $R_{load} = 25$  k $\Omega$

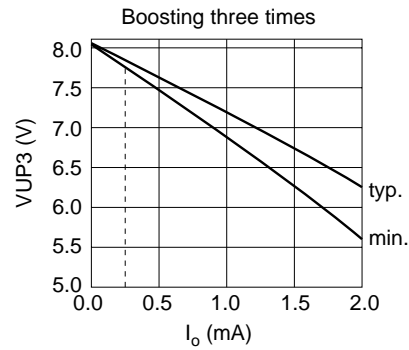


Test condition:  $V_{ci} = V_{CC}$ ,  $f_{cp} = 160$  kHz,  
 $T_a = 25^\circ\text{C}$ ,  $R_{load} = 25$  k $\Omega$

(2) VUP2, VUP3 vs  $I_o$

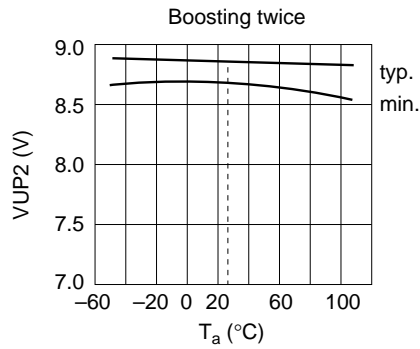


Test condition:  $V_{ci} = V_{CC} = 4.5V$ ,  
 $R_f = 200\text{ k}\Omega$ ,  $T_a = 25^\circ\text{C}$

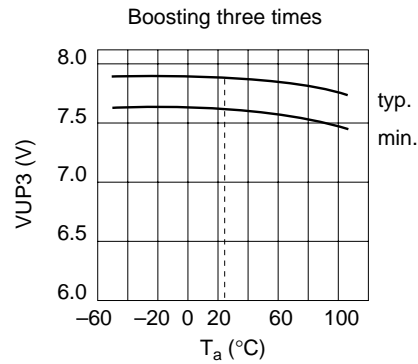


Test condition:  $V_{ci} = V_{CC} = 2.7V$ ,  
 $R_f = 160\text{ k}\Omega$ ,  $T_a = 25^\circ\text{C}$

(3) VUP2, VUP3 vs  $T_a$

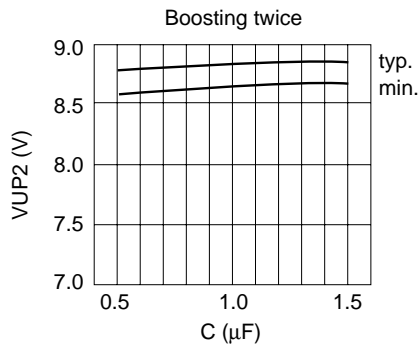


Test condition:  $V_{ci} = V_{CC} = 4.5V$ ,  
 $R_f = 200\text{ k}\Omega$ ,  $I_o = 0.25\text{ mA}$

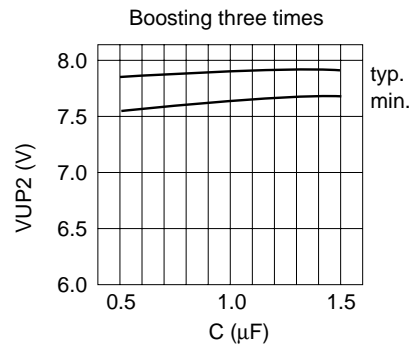


Test condition:  $V_{ci} = V_{CC} = 2.7V$ ,  
 $R_f = 160\text{ k}\Omega$ ,  $I_o = 0.25\text{ mA}$

(4) VUP2, VUP3 vs capacitance



Test condition:  $V_{ci} = V_{CC} = 4.5V$ ,  
 $R_f = 200\text{ k}\Omega$ ,  $I_o = 0.25\text{ mA}$



Test condition:  $V_{ci} = V_{CC} = 2.7V$ ,  
 $R_f = 160\text{ k}\Omega$ ,  $I_o = 0.25\text{ mA}$

22. Must maintain (“High”)  $V_{CC} \geq V_{ci}$  (“Low”).

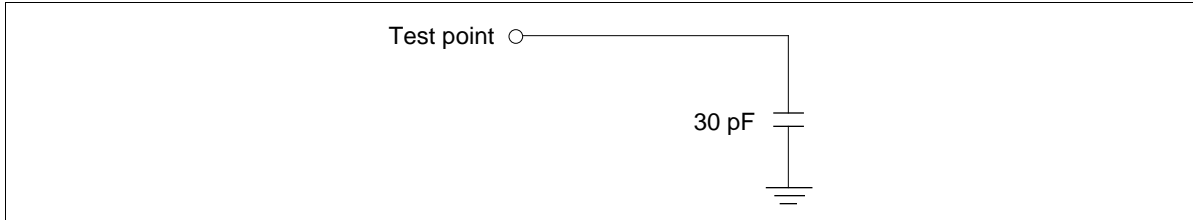
---

## HD66720

---

### Load Circuits

#### AC Characteristics Test Load Circuits



Timing Characteristics

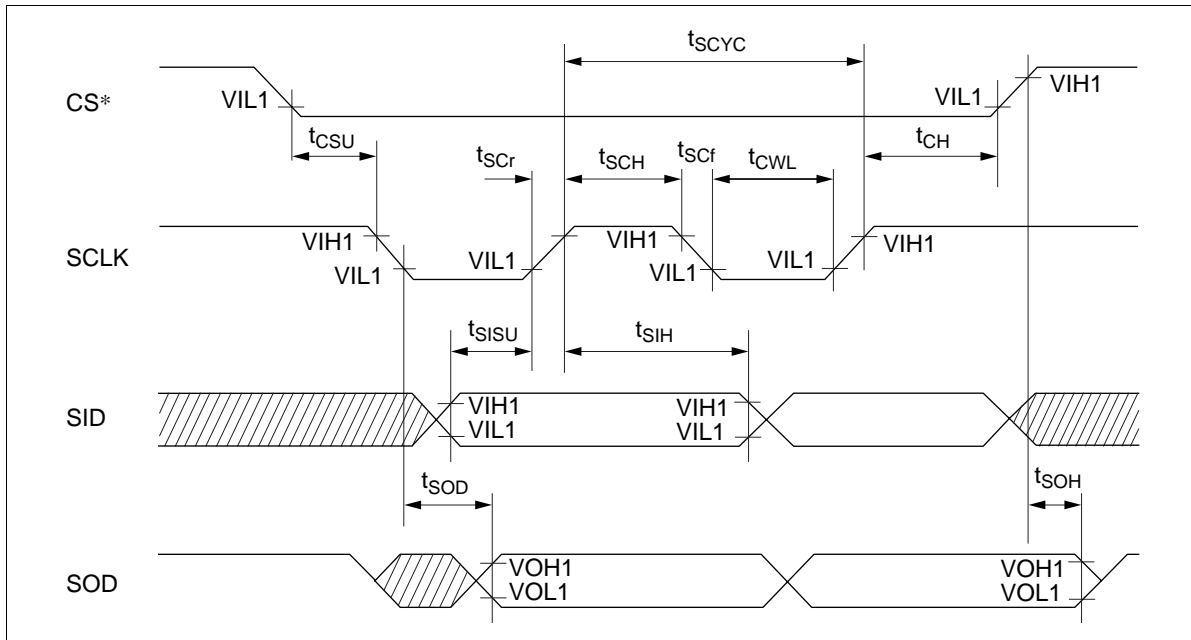


Figure 53 Serial Interface Timing

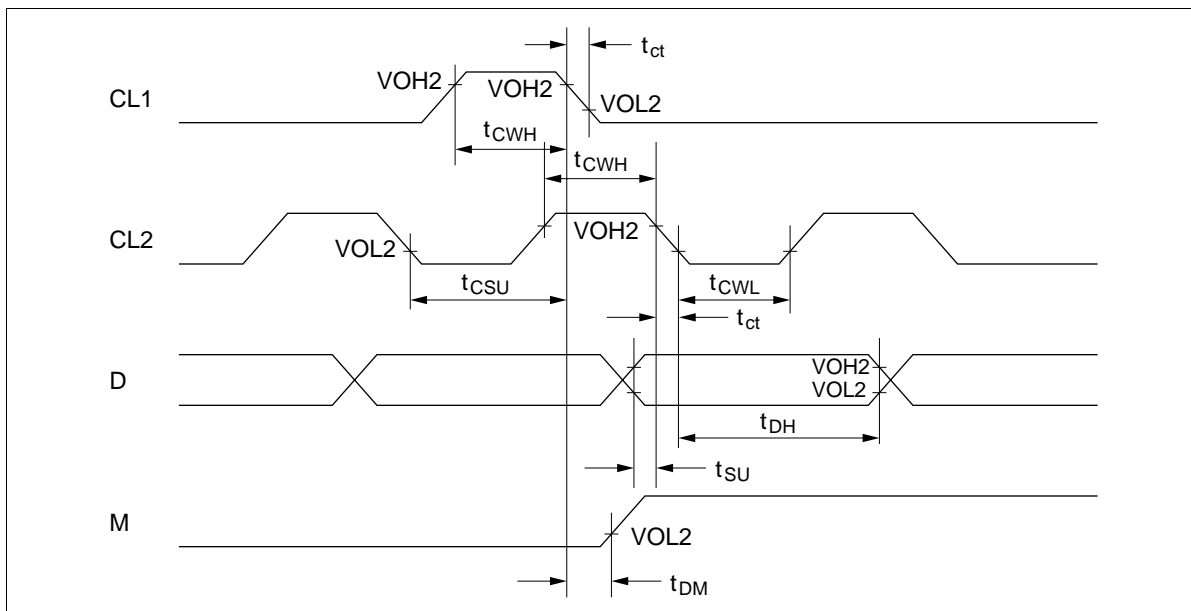
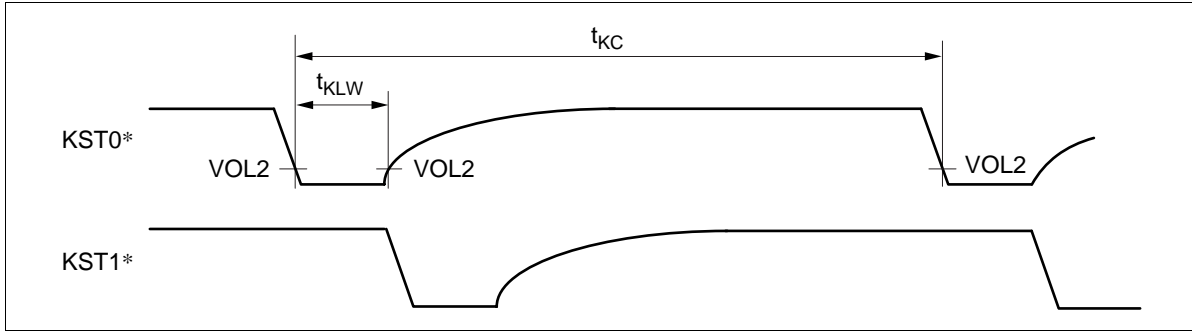
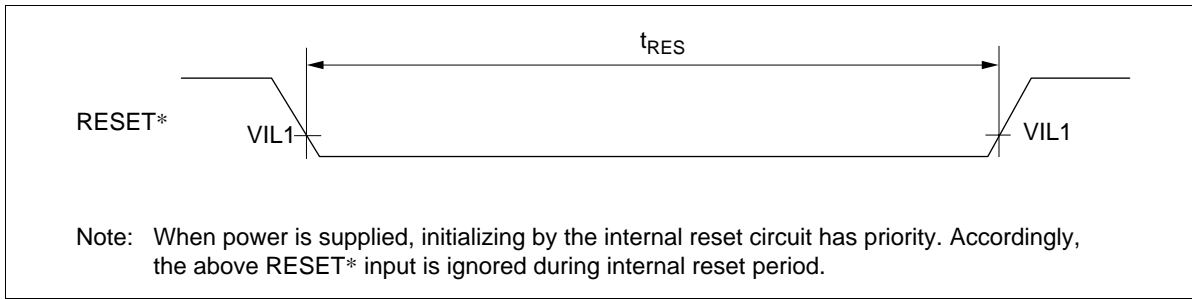


Figure 54 Interface Timing with Extension Driver

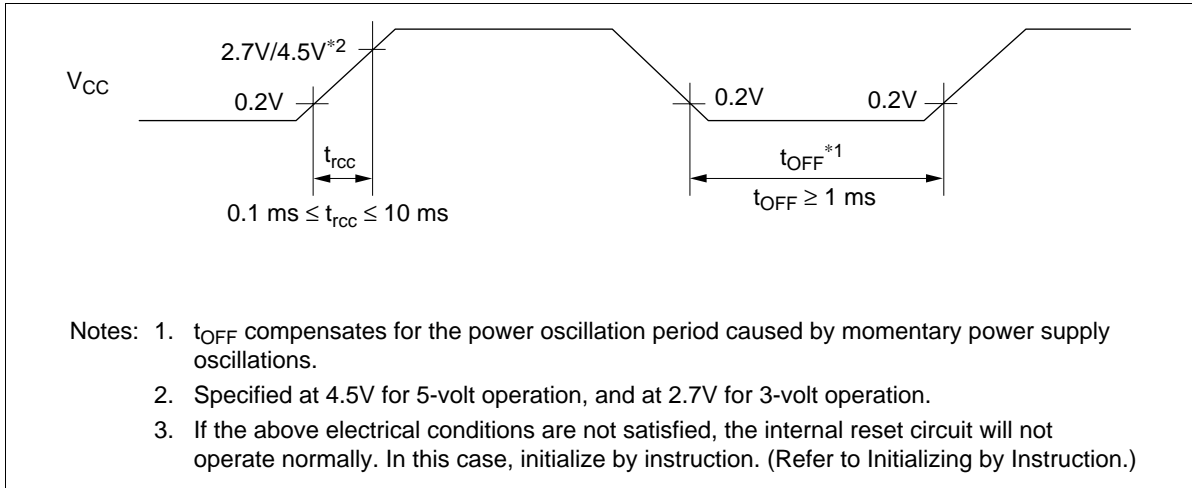


**Figure 55 Key Strobe Timing**



Note: When power is supplied, initializing by the internal reset circuit has priority. Accordingly, the above RESET\* input is ignored during internal reset period.

**Figure 56 Reset Timing**



- Notes:
1.  $t_{OFF}$  compensates for the power oscillation period caused by momentary power supply oscillations.
  2. Specified at 4.5V for 5-volt operation, and at 2.7V for 3-volt operation.
  3. If the above electrical conditions are not satisfied, the internal reset circuit will not operate normally. In this case, initialize by instruction. (Refer to Initializing by Instruction.)

**Figure 57 Power Supply Sequence**